

Mackinaw Timber Building

12' x 8', 12' x 12', 12' x 16', 12' x 20'

- BEFORE YOU BEGIN -

■ First...

Read these instructions thoroughly before you begin assembly. Assembly is easiest if you follow the steps in the order shown. In a drawing, a dotted line represents a part hidden from view (like a part under a panel). Lumber is graded from only one side. Check the part for the most attractive face and make sure to face it to the outside.

■ Check all parts

Compare the parts you have to the list on page 2. If a part is missing, circle the part in question in parts list and call us toll-free at 1-800-437-0784.

■ Assistance required

We recommend that you assemble this building on level ground, in the location it will be used. Assistance is necessary to handle, fit, and secure some components. Two people are needed for some steps.

■ Squareness is very Important!

Keeping all 90° corners and 90° perpendiculars square throughout the assembly of this building will make each succeeding step easier and is necessary to assure that all components fit together properly.

■ Check local zoning

Before starting construction, check with your local building code official for any required permits, variances, etc.

Always wear OSHA-APPROVED safety glasses throughout the assembly process

#16625

■ Supplies required

- 3 Tubes of Caulk (Not Supplied with Kit)

■ Tools required

- Hammer
- Phillips Screwdriver
- Level
- Tape Measure
- Pencil
- Ladder

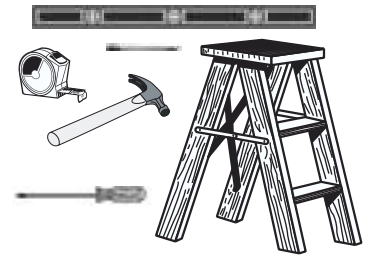

■ Optional tools

- Electric Drill w/ #2 Phillips Tip
- Chalk Line
- Square
- Nail Pouch



Visit us on the Web at:
www.HandyHome.com



Shown 12' x 20' Mackinaw with Landscaping and Optional Porch (not Included)

Terms and abbreviations

NATIONAL STANDARD LUMBER SIZES

Nominal size	Actual size
1 x 2 =	3/4" x 1-1/2"
1 x 3 =	3/4" x 2-1/2"
1 x 4 =	3/4" x 3-1/2"
2 x 3 =	1-1/2" x 2-1/2"

Nails and Screws Actual Chart Size

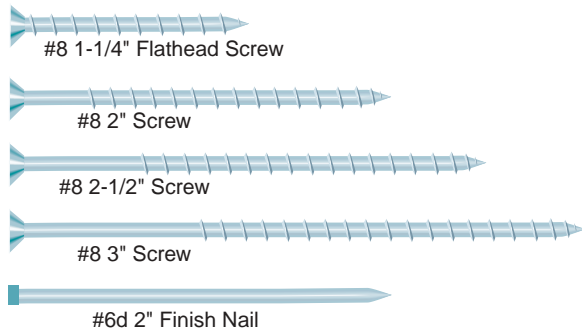

Reading a tape Measure:

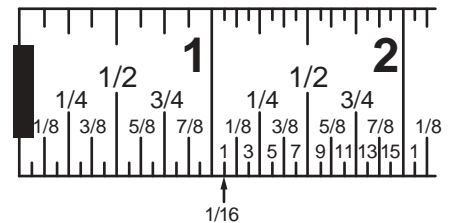

THE FOLLOWING TERMS AND ABBREVIATIONS ARE USED IN THESE INSTRUCTIONS AND ARE DEFINED AS FOLLOWS:

- **Dimension lumber:** lumber ranging from 1-1/2 to 5 inches in thickness and up to 12 inches in width. Most commonly used in framing structure and floors
- **Drip edge:** a metal product of various shapes which is nailed or stapled to the edges of the roof or floor to allow water to drip free of the building
- **Joist:** one of a series of parallel framing members used to support floor or ceiling loads
- **Level (carpenter's):** tool used for determining true horizontal, vertical, or angular direction by centering a bubble in a liquid-filled tube
- **Nails:** used for general construction, having a round shaft and a flat head. Two sizes of nails are used for this project :
 - #6d 2" nail
 - #10d 3" nail

- **On center:** a method of indicating the spacing of framing members by stating the measurement from the center of one member to the center of the succeeding one
- **Plate:** dimension lumber which runs perpendicular to studs and to which studs are nailed for framing
- **Rack:** (as in "rack the frame") removing the "twist" from a frame in order to align members square and parallel
- **Roofing:** material—wood, metal, asphalt-type, etc. — installed on the roof panels to protect it (roof) and weatherproof the structure
- **Roof panels:** panels fastened to the rafters to which the shingles or other roof covering are attached
- **Shim:** (as in "shim to the ground") a thin wedge of wood or other material placed between

the floor kit frame and the ground to adjust relative position or level. We recommend cedar shims

- **Sill plate:** the strip of wood that lies immediately on top of a concrete foundation in wood frame construction
- **Studs:** one of a series of vertical supports used in wall framing
- **Toe-nail:** (as in "toe-nail through stud into floor") adjoining of components using a nail or screw at an angle
- **Truss:** a structural unit consisting of various members arranged to provide rigid support over wide spans with a minimum amount of material
- **Vapor barrier:** a watertight material used to prevent the passage of moisture or water vapor into or through structural elements (floors, walls, ceilings)

FLOOR PANEL WALL AND LAYOUT

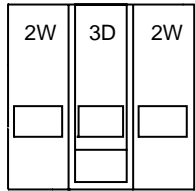
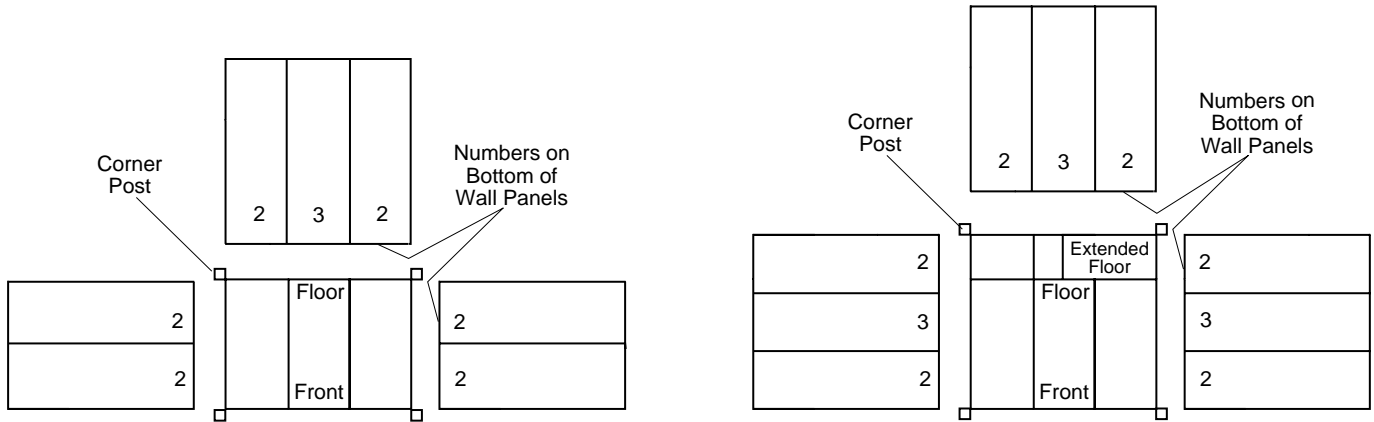

12' x 8' Building

The #2W can be interchanged with any #2 panel.
 The 3D can be interchanged with and #3 panel.

Only on the Front and Back of the Building
 The 2 and 2W panels and the 3D panel can be interchanged. 3D must be on Front or Back Gable End.

Example

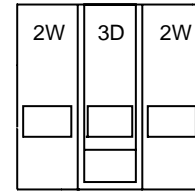

12' x 12' Building

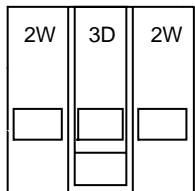
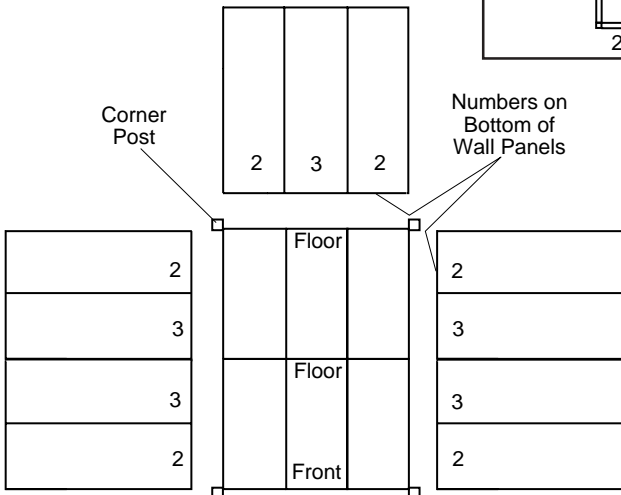

12' x 16' Building

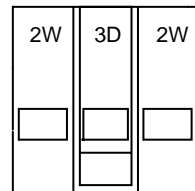
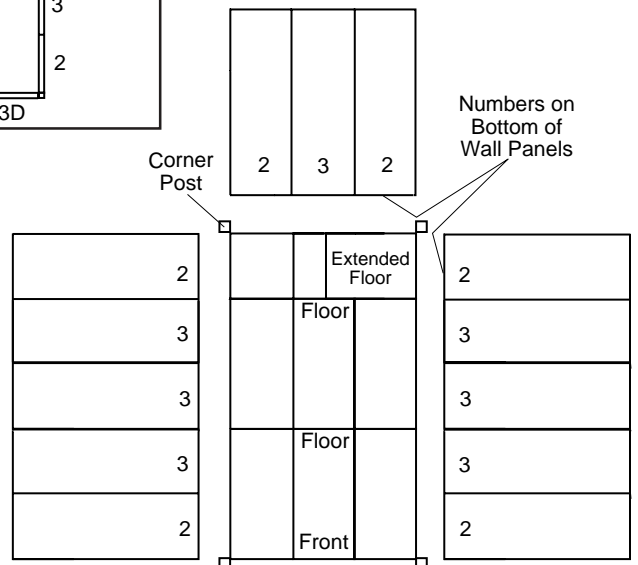

12' x 20' Building

1

SITE PREPARATION

You must build your timber building on a floor system.

Note: You must construct your building on a floor system, either wooden or concrete. A floor system is not supplied with your building kit. Handy Home Products optional floor kit and extender floor kits are available from your local dealer.

Regardless of type of flooring used, adhere to following recommendations before beginning assembly:

- Site must be properly leveled.
- Site should have natural drainage to eliminate puddling under and around building.
- Site should be covered with plastic film to provide vapor barrier under foundation.

A. For wooden floor, refer to instructions on following pages.

B. For concrete floor, construct 4" concrete slab system, as shown. Bolt or nail 2x4" treated lumber plates to support wall panels to slab. Ensure assembly surface is level before beginning construction of building.

NOTE: Bolts for slab should be countersunk.

A

Wood

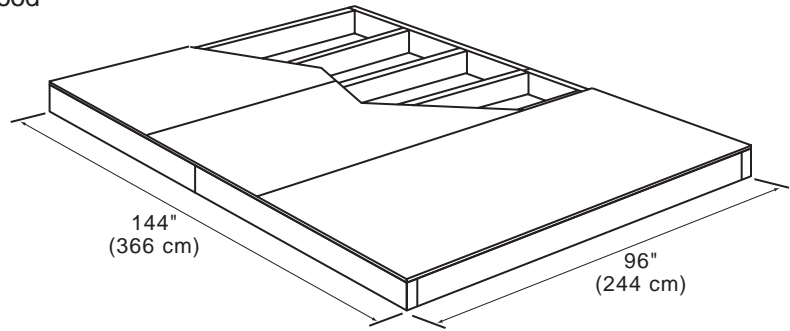

B

Concrete

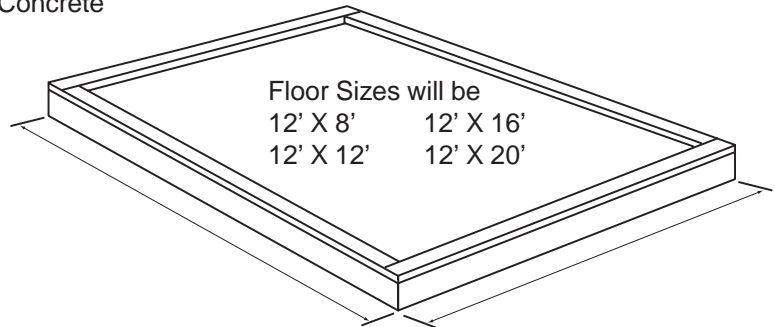

Note: No concrete is needed for optional porch area.

Slab (Floor) Size for Extended Buildings

Slab Size	Building Size
144" x 96"	12' x 8' (366 x 244 cm)
144" x 144"	12' x 12' (366 x 366 cm)
144" x 192"	12' x 16' (366 x 488 cm)
144" x 240"	12' x 20' (366 x 610 cm)

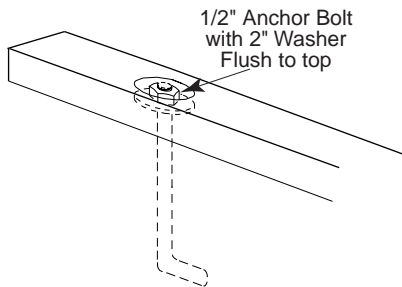

Note: Installation recommendation...

Position 1x2 Drip Edge around entire edge of floor with 2" leg on top of floor and the 1" leg covering edge of plywood deck or treated sill plate fastened with 1" Roof Nails. (Not supplied with kit)

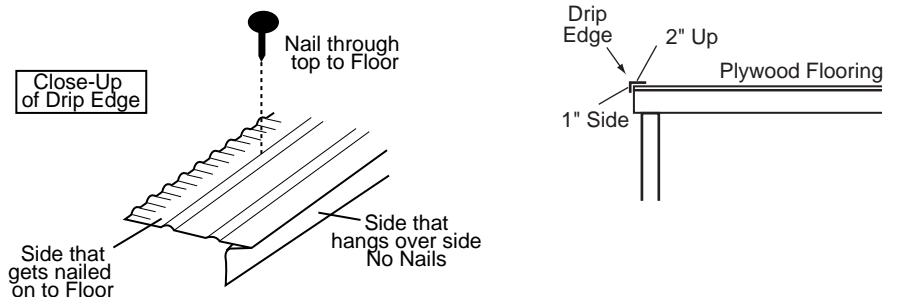

1

MACKINAW 12' x 8' FLOOR

- 12' x 8' Wooden Floor Kit Parts List
- 4 - Floor Bond Boards 2x6x72" (A)
 - 7 - Floor Joist 2x6x93" (B)
 - 3 - Floor Panels 3/4"x48"x96"
 - 1 - Package of Nails, 16d Nails, 6d Nails
 - 6 - Packing material 2x3x15-3/4"

1A

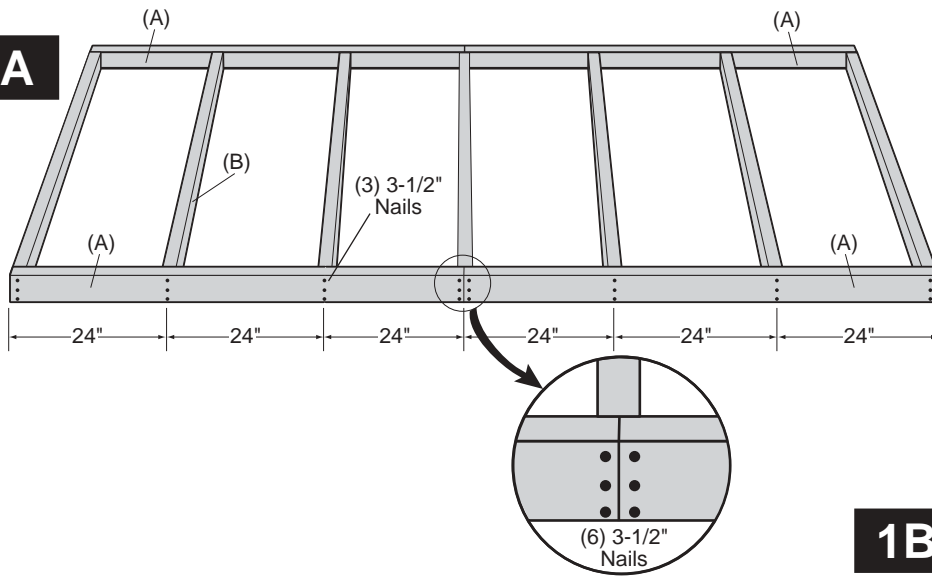

1A - For Floor Unit, arrange 4-72" Floor Bond Boards part (A) and 7-93" Floor Joists part (B) as shown.

Use 3-1/2" nails nailing three times through Bond Boards into each end of each Joist. Use (6) 3-1/2" nails where Floor Bond Boards butt together.

1-B: Completed Floor Frame should be positioned at building site and leveled, using shims between floor and ground, before proceeding to Floor Panel Attachment.

Square frame by making corner-to-corner measurements (X to X and Y to Y) the same.

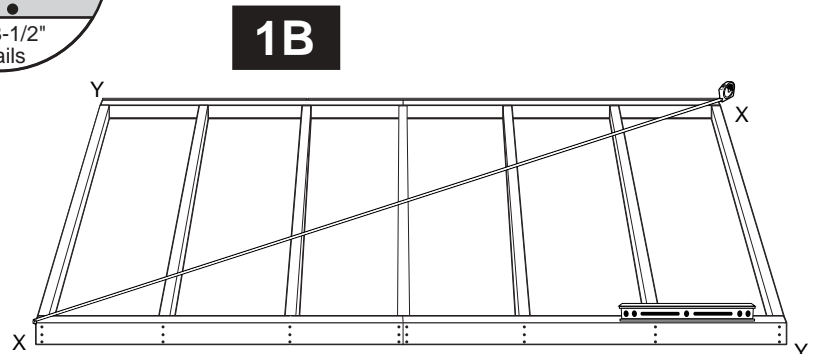

1C - Position a 48"x96" Floor Panel (1) flush to front and left side of Floor Frame. Panel should be centered on third Floor Joist part (B). Secure Panel with 2-2" nails at outside front and back corner and 1-2" nail at other two inside corners.

Position a 48"x96" Floor Panel (2) flush against Floor Panel (1). Panel should be centered on fifth Floor Joist part (B). Secure Panel with 1-2" nail at each corner.

Apply 48"x96" Floor Panel (3). Nail with 2-2" nails at outside corners and with 1-2" nail at each inside corner.

Position 48"x96" Floor Panel (3) tight against Floor Panel (2) and flush to front and side of Floor Frame. Nail same as Panel (1).

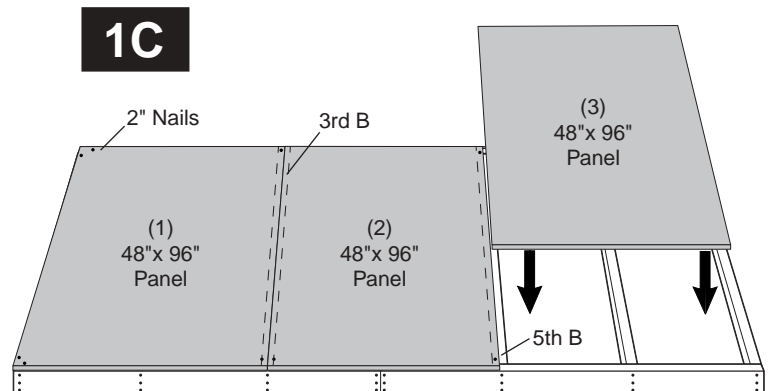

1D - With all Floor Panels flush to outside edges of Frame and properly centered on Joists, nail with 2" nails every 12" through Floor Panels into all Floor Bond Boards and all Floor Joists as shown.

Your Floor is now complete. Be sure it is properly positioned and leveled to ground before beginning assembly of Handy Hut Timber Building.

Recommended (Not Supplied with Kit)

Position 1 x 2 Drip Edge around entire edge of floor; fasten with 1" Roof nails (Not supplied with kit.) Caulk on top of this when assembling walls.

1D

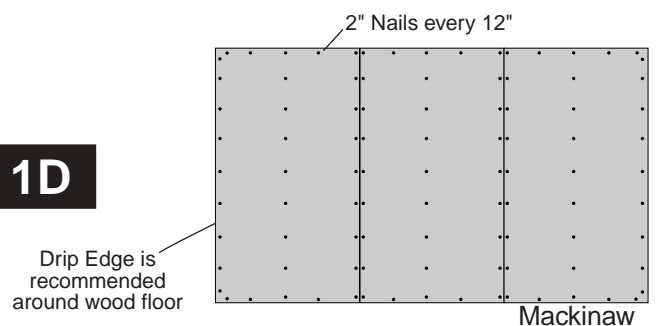

1x MACKINAW 12' x 4' EXTENDED FLOOR

12' x 4' Wooden Floor Kit Parts List

- 4 - Floor Bond Boards 2x6x72" (A)
- 7 - Floor Joist 2x6x45" (C)
- 1 - Floor Panels 48"x24"x3/4"
- 1 - Floor Panels 48"x48"x3/4"
- 1 - Floor Panels 48"x72"x3/4"
- 1 - Floor Panels 48"x72"x3/4"
- 6 - Packing material 2x3x15-3/4"
- 1 - Package of Nails - 16d Nails, 6d Nails

1-XA

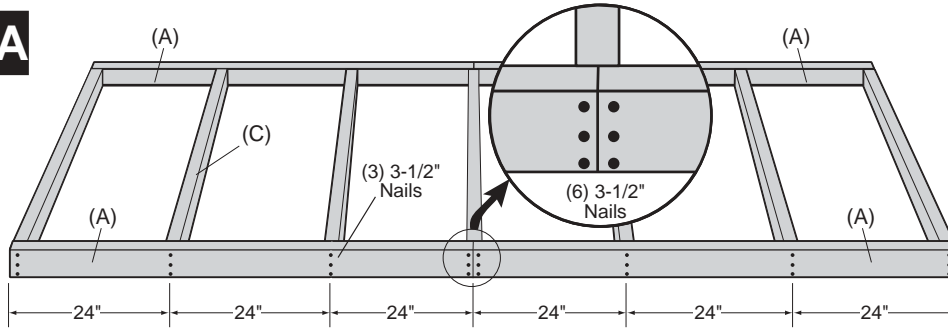

1X-A: For Floor Unit, arrange 4-72' Floor Bond Boards part (A) and 7-45" Floor Joists part (C) as shown.

Use 3-1/2" nails nailing three times through Bond Boards into each end of each Joist. Use (6) 3-1/2" nails where Floor Bond Boards butt together.

1X-B: Place 4' extender floor frame to 12x8 floor frame with (2) 3-1/2" nails between joists. Completed Floor Frame should be positioned at building site and leveled, using shims between floor and ground, before proceeding to Floor Panel Attachment.

Attach floors together with 3-1/2" nails.

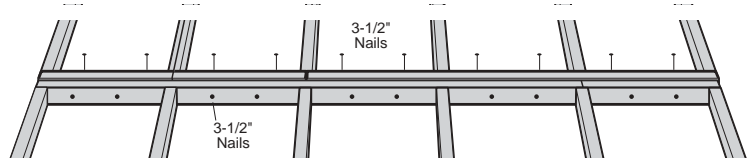

Square frame by making corner-to-corner measurements (X to X and Y to Y) the same.

1X-B

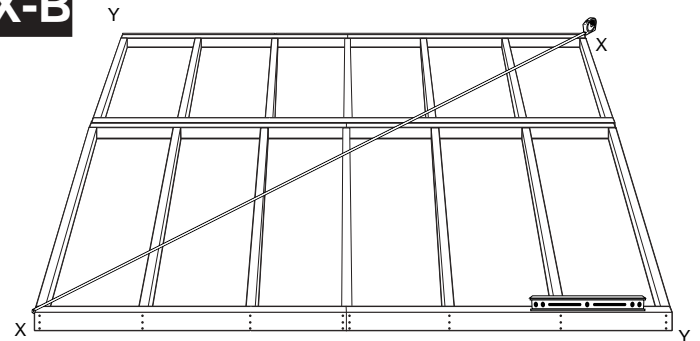

1X-C: Position a 48"x48" Floor Panel (1) flush to front and left side of Floor Frame. Panel should be centered on third Floor Joist part (C). Secure Panel with 2-2" nails at outside front corner and 1-2" nail at other two corners.

Position a 24"x48" Floor Panel (2) flush against Floor Panel (1). Panel should be centered on fourth Floor Joist part (C). Secure Panel with 1-2" nail at each corner.

1X-C

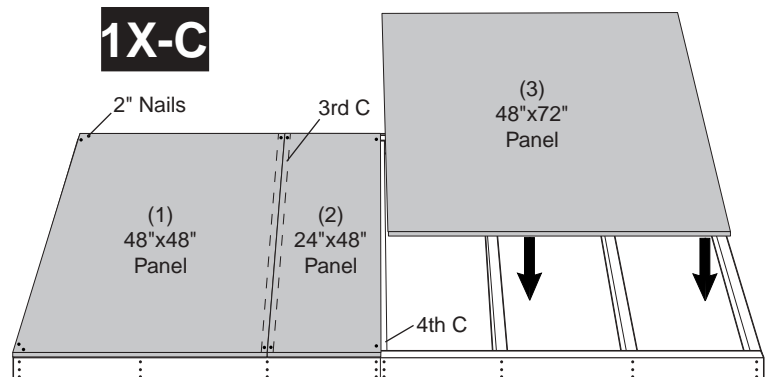

Position 48"x72" Floor Panel (3) tight against Floor Panel (2) and flush to front and side of Floor Frame. Nail same as Panel (1).

1X-D: With all Floor Panels flush to outside edges of Frame and properly centered on Joists, nail with 2" nails every 12" through Floor Panels into all Floor Bond Boards and all Floor Joists as shown.

Your Floor is now complete. Be sure it is properly positioned and leveled to ground before beginning assembly of Handy Hut Timber Building.

Extended Floor Panels

Recommended (Not Supplied with Kit)

Position 1 x 2 Drip Edge around entire edge of floor; fasten with 1" Roof nails (Not supplied with kit.) Caulk on top of this when assembling walls.

1X-D

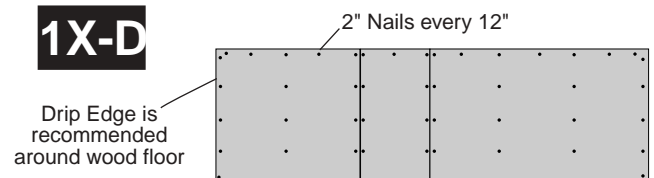

2

Erecting Walls

<input type="checkbox"/> 4 - Corner Posts	1-7/8"x1-7/8"x80-3/4"
<input type="checkbox"/> 6 - (#2) End Wall Panels	46-5/8"x80-3/4"
<input type="checkbox"/> 1 - (#3) Middle Wall Panel	48"x80-3/4"
<input type="checkbox"/> 2 - (#2W) Window Panels	46-5/8"x80-3/4"
<input type="checkbox"/> 1 - (#3D) Door Panel	48"x80-3/4"
Each 4' Extender	
<input type="checkbox"/> 2 - (#3) Middle Wall Panels	48"x80-3/4"

Note: Before beginning, make sure the floor is square & level.

2-A: Find the center of the floor on each side and mark center. In the front and back, from center measure 70-1/2" and make a mark on either side of center mark. Use one of the following dimensions. On the side, measure 46-1/2" from the center and make a mark for a **8' side wall**. On the side, measure 70-1/2" from the center and make a mark for a **12' side wall**. On the side, measure 94-1/2" from the center and make a mark for a **16' side wall**. On the side, measure 118-1/2" from the center and make a mark for a **20' side wall**. Now measure diagonally between the other pair of corner marks. These measurements should be identical! If they are not, adjust the corner marks slightly so the measurements are identical. Mark or chalk a line between each corner mark, parallel with the outer edge of the floor. The perfect rectangle or square you have created will serve as a guide to help you keep the inside of your building panels aligned & square.

2-A

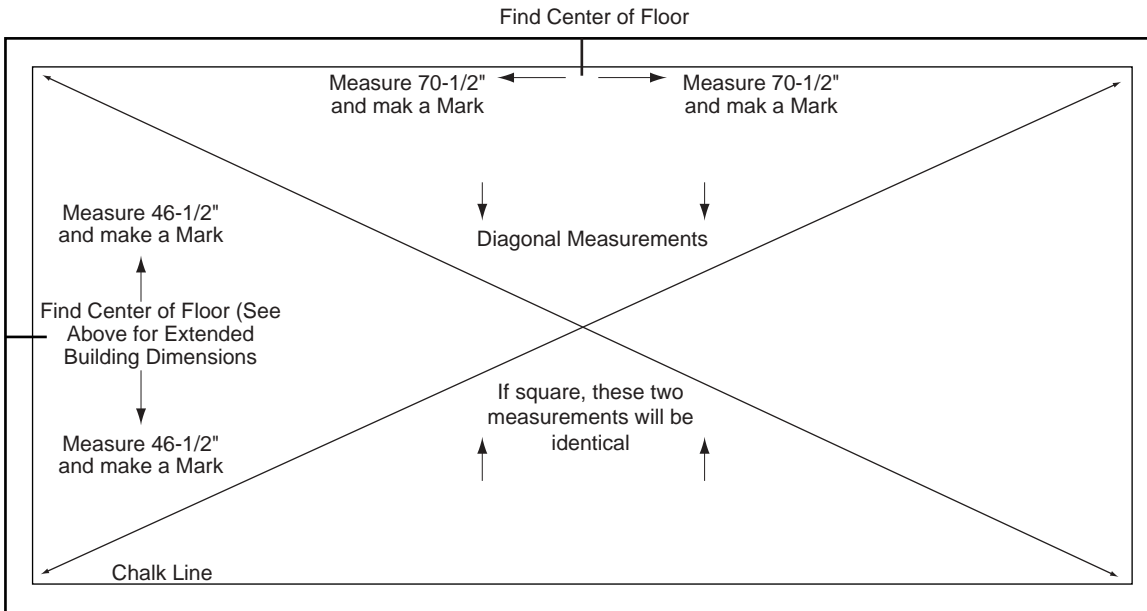

2-B: When attaching wall panels, keep the square end to the floor and to the outside. The wall panels will overhang the floor frame about 1/2". If drip edge is used, wall will approximately line up with drip edge. Secure only 1 wall #2 with 2/1-2" screws until all panels are screwed together, see 2-G.

2-B

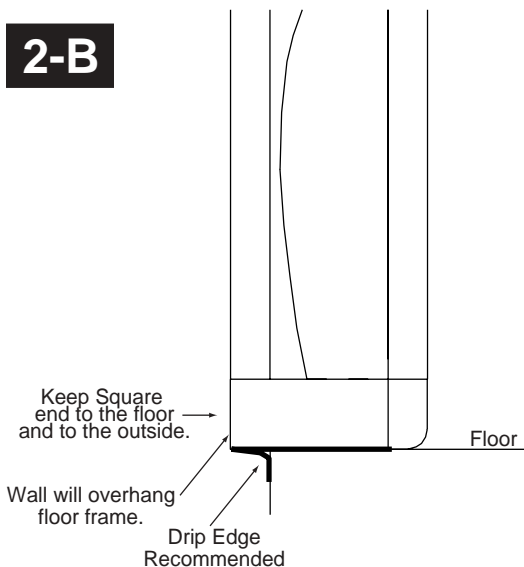

2-C

2-C: Attach a 1 7/8"X1 7/8" corner post to one of the Front Wall #2W wall panels using five 2 1/2" screws keeping the Sharp Corner to the inside, see 2-D for screw location. Keep the tops of all wall panels even and be sure to caulk all seams where panels join together - including at the floor and the roof.

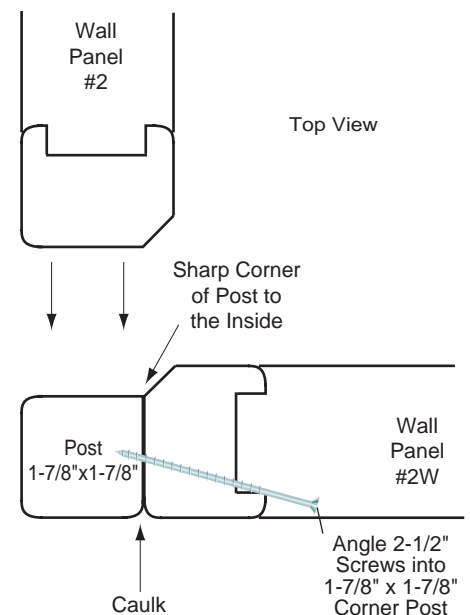

2

Erecting Walls Continued

2-D: From inside, use 2-1/2" screws evenly spaced along the inside wall seam, secure post. Now, stand the #2W panel upright (The bottom of every panel is marked with its' unit #) along with a #2 panel to form the front left corner of the building (refer frequently to Page 4 to maintain correct panel order). Keeping the tops of the panels even, fasten the panels together using (5) 2-1/2" screws evenly spaced along the outside of the wall and (4) 2-1/2" screws along the inside.

2-D

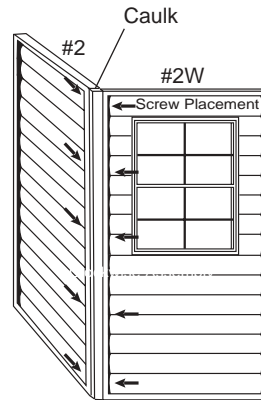

Outside View

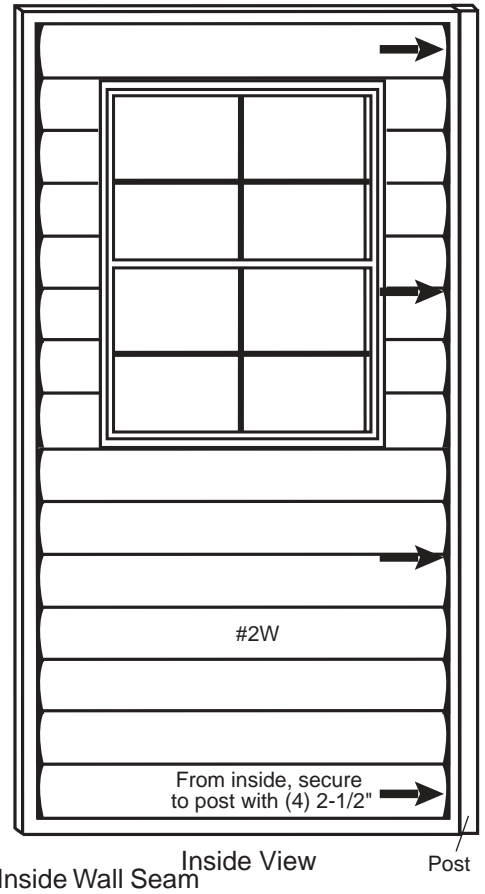

Inside View
Post
From inside, secure to post with (4) 2-1/2"

2-E

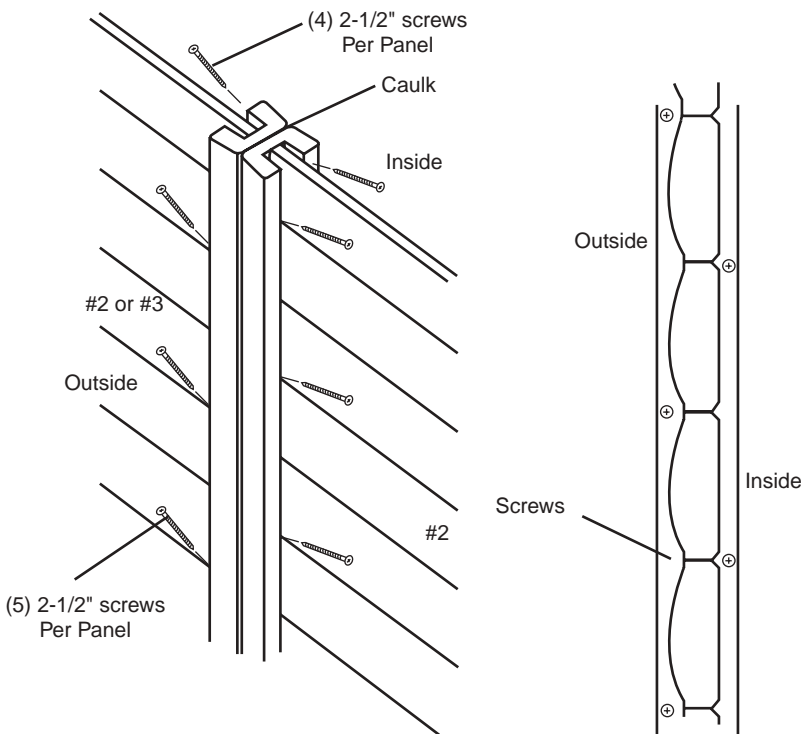

2-E: Place next Side Wall Panel #2 on #3, see page 4. Keeping the tops of the panels even, fasten the panels together using (5) 2-1/2" screws evenly spaced along the outside of the wall and (4) 2-1/2" screws along the inside.

2-F: See step 2G then Continue Assembling walls in a Clockwise direction until all wall Panels are screwed together.

2-F

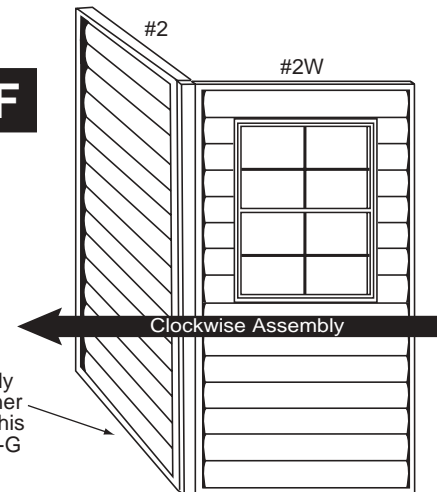

Outside View

2 Erecting Walls Continued

2-G: Fasten this assembled Left Side #2 and Front #2W Panels to the floor by screwing one 2 1/2" screw through the bottom plate of the #2W panel into the floor at the corner (only fasten this panel to the floor with one screw at this time). Continue assembling the with balance of Wall Panels, (See Page 4 for Wall Layout) clockwise, joining upright adjoining the panel already installed, and screw the following panel with (5) 2-1/2" screws evenly spaced along the outside wall & four along the inside. Repeat this pattern for fastening all the remaining wall panels together. Remember to install a corner post in every corner. As stated earlier, refer frequently to Page 4 to maintain the correct panel order. With the exception of front corner panel #2W as explained above, do not attach any other wall panels to the floor at this time! Also remember that the wall overhangs the floor by about 1/2" if no drip edge is used.

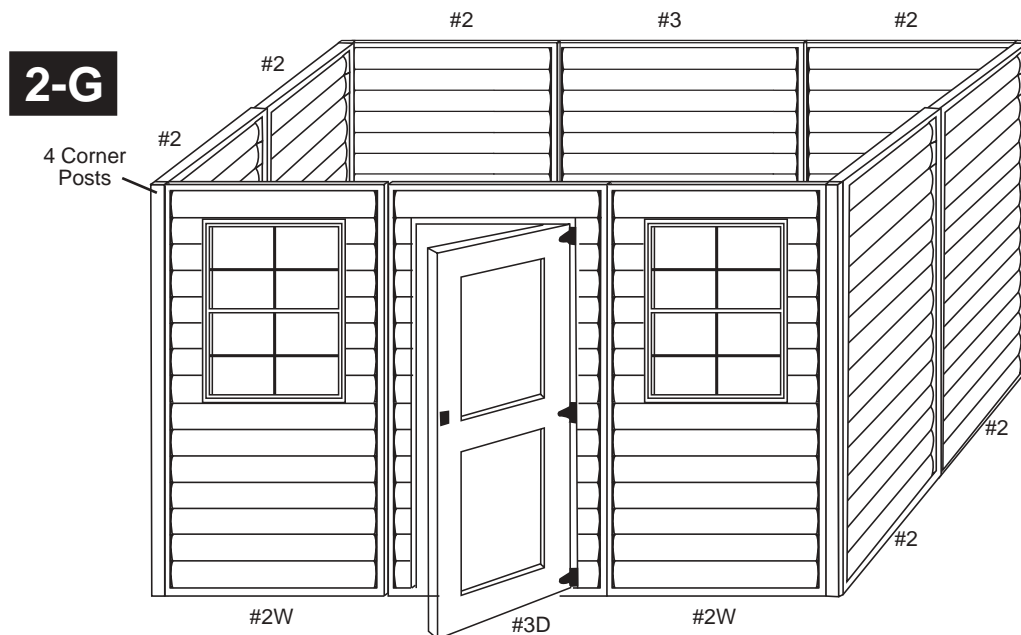

2-H: Double check to be sure all walls are square and parallel to lines drawn on floor 2A. Note: You may need to readjust the one screw from earlier on Front Corner #2W. Starting at the front of the building, screw the wall to the floor using (4) 2-1/2" inch screws in each wall panels evenly spaced along the outside of the building.

Next, screw the left side wall to the floor along the outside of the building making sure to keep the inside aligned with the chalk line. Now follow the procedure described above for the right side wall, & then for the rear wall.

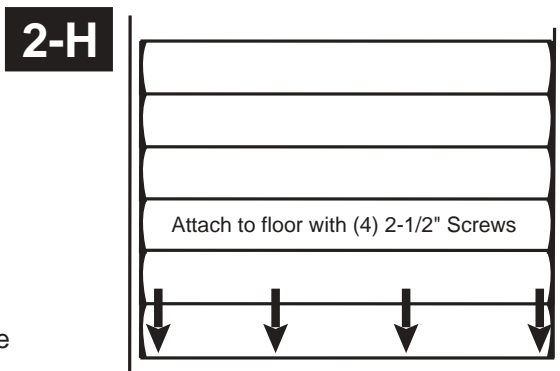

NOTE: It is possible that the right wall & the rear wall will not align perfectly with the chalk line. If this occurs simply make sure to keep these walls parallel to their respective chalk lines, so that the amount of error is kept even. By doing this, your building will remain square!

3

Wall Bracing

3-A: Starting at the left fasten the wall brace together with (12) 1-1/4" screws using 3 – 1x3x72" as shown. The brace will be about 150" long. Position the wall brace 72" from the front wall on top of the wall panels and fasten with (2) 2" screws through the 1x3 into each of the wall panel. Maintain 145" outside dimension on wall panels. Move your wall brace to the next wall panel and reattach as you assemble your roof if your building is longer than 96". At this point, measure diagonally X to X and Y to Y to make sure building is square.

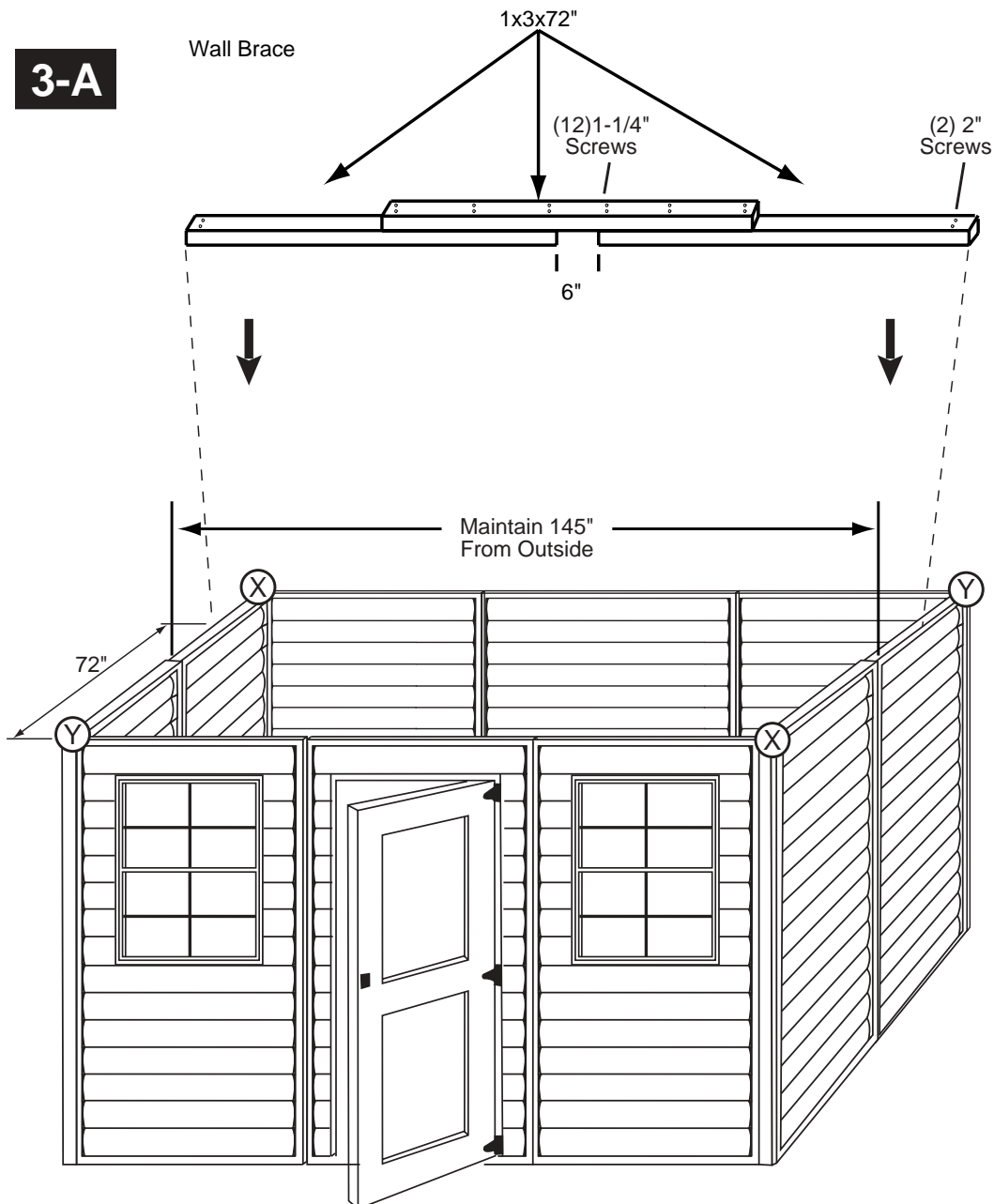

4

Attaching Gables

- 2 - Right Gable Panel
- 2 - Left Gable Panel

Note: During this step, remember to apply caulk to all seams where panels join together.

4-A: Measure the width of the building & place a mark in the exact middle on top of the front wall (this mark should be at approx. 72 1/2"). Select one of the #7 gable panels & place it on the top of the front wall making sure to keep the round surface of the log facing the outside. Align the inside edge of the gable panel with the inside edge of the wall & slide the gable panel toward the center of the wall until it lines up with the building's center mark. Attach the gable panel to the wall by screwing through its bottom plate into the top of the wall using (5) 2" screws. Next, select one of the #8 gable panels & place it on top of the front wall with the round surface of the log facing the outside. Align the inside edge of the gable panel with the inside edge of the wall & slide the gable panel toward the center of the wall until it butts up against the #7 gable panel. Again secure with (5) 2" screws through bottom plate of gable and use (3) 2" screws to attach the vertical gable seam. Repeat this step for the back of building.

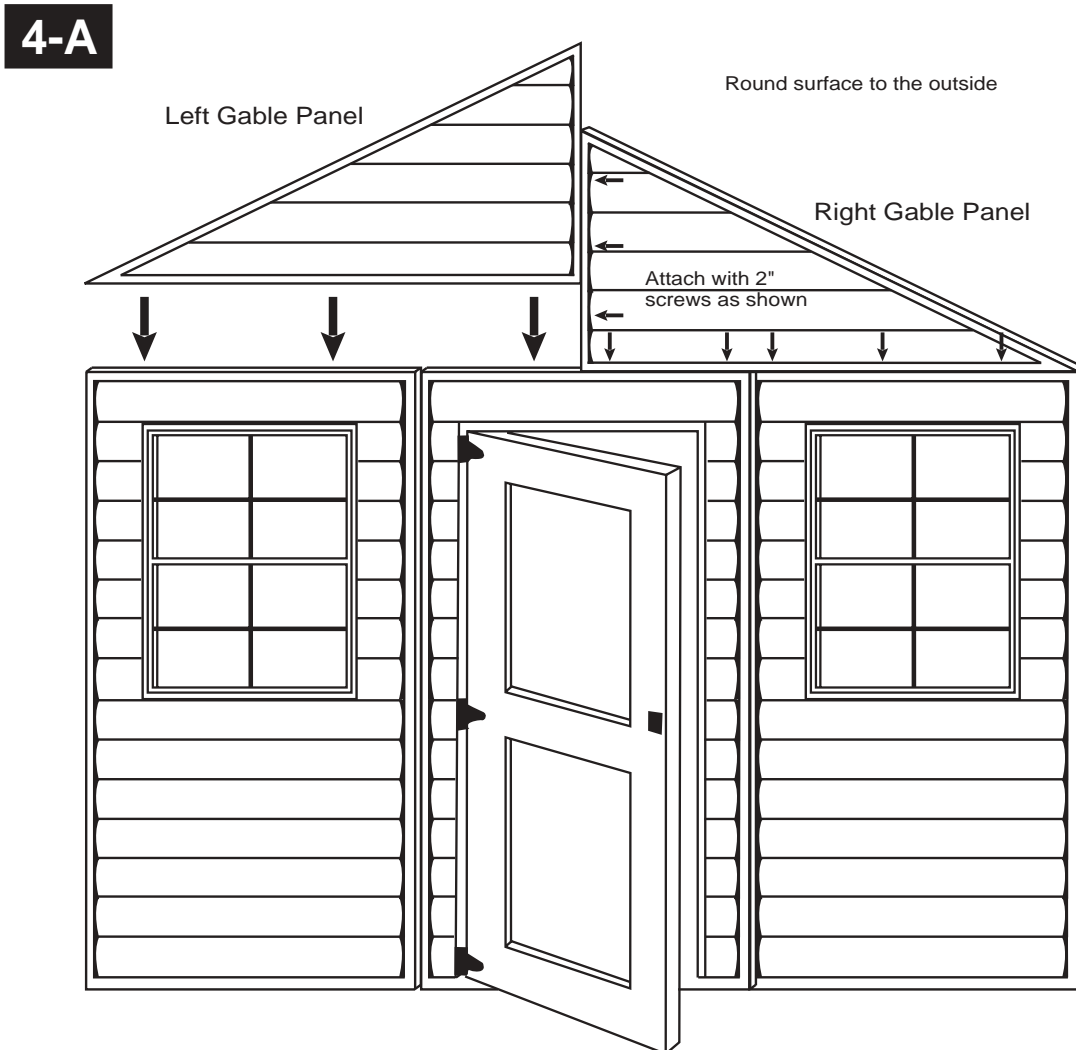

5

Assemble Collar Ties

- Basic 12 x 8 Building Parts
- 2 - Angled Collar Tie 1x6x70"
 - 1 - Assembled Collar Tie Block 3"x3-1/2"x23"

- Each 4' Extender Parts
- 2 - Angled Collar Tie 1x6x70"
 - 1 - Assembled Collar Tie Block 3"x3-1/2"x23"

Note: If you are planning on installing a loft, some collar ties will not be used. A loft can only be installed in a 12x12, 12x16 and 12x20 Mackinaw. A 12x12 will have no collar ties, a 12x16 will have one collar tie and a 12x20 will have two collar ties if a loft is being installed.

5-A: Position and center assembled collar tie block 3"x3-1/2"x23" and 1x6x70" angled side Collar Tie on a flat surface as shown, fasten together with (6) 2-1/2" screws on each side as shown in the screw pattern, 2" from the end and 1-1/2" apart.

5-A

- 1 Collar Tie for 8' Building
- 2 Collar Ties for 12' Building
- 3 Collar Ties for 16' Building
- 4 Collar Ties for 20' Building

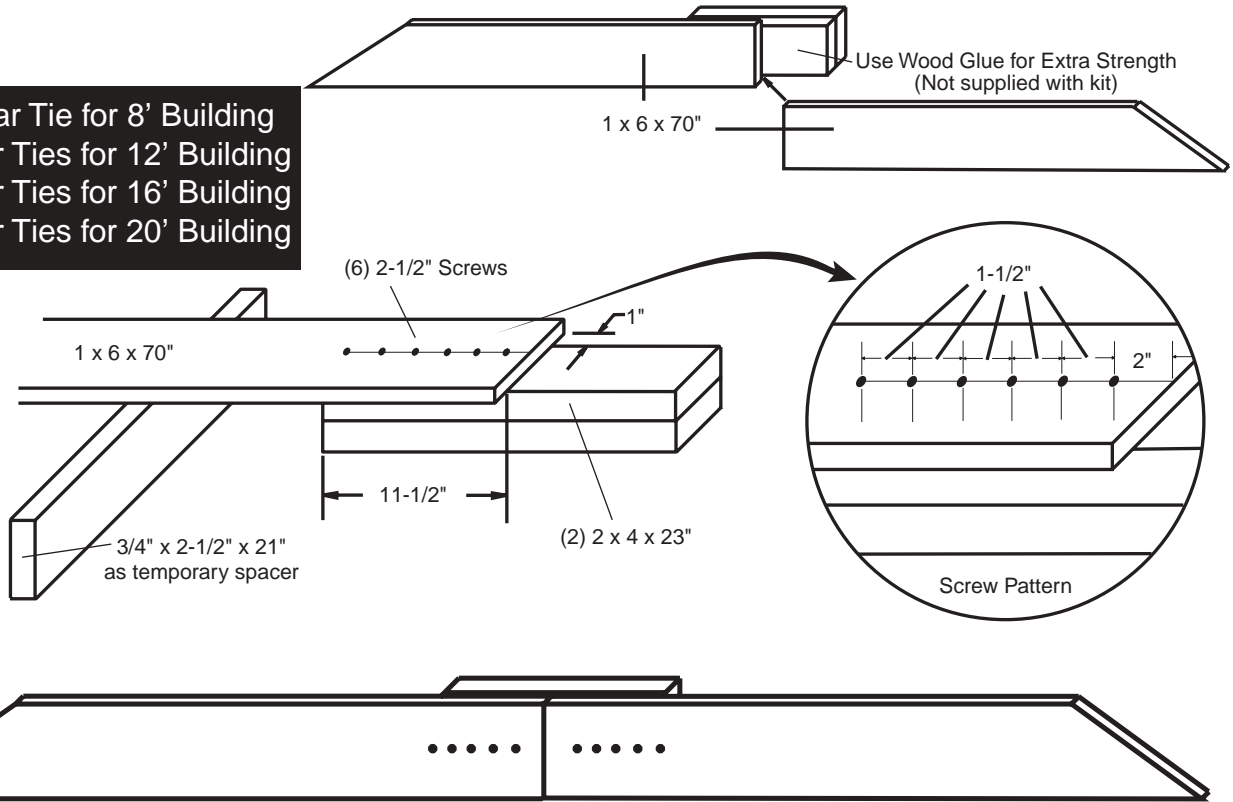

Note: The collar ties are only part way assembled at this time. Later in the manual they will be finished.

6

Assemble Ridge Support

- 3 - Temp Wall Brace and Ridge boards 1x3x72"
- 1 - Ridge Support Spacer 2x4x4"

6-A: Roof ridge support pole included (must be assembled) with parts supplied in kit. Use the roof ridge support pole pictured to hold the roof panel up in center while you and a helper screw the panel in place. Lay out the (3) 1x3x72" boards as shown in diagram and fasten together with (6) 2" screws from each side. Spread 1x3 forks apart and insert 2x4 spacer block to make 4" between the forks and 6" inset. Screw together with 2 - 2" screws from each side.

6-A

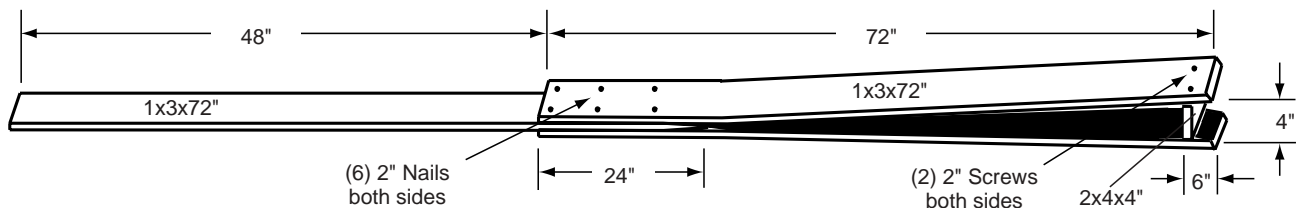

7 Installing Roof Panels

- 6 - Roof Panels
 - 6 - Rafter 2-1/2"x3"x79-3/4"
 - 1 - Assembled Collar Tie Half
 - 2 - Temp Spacer 3/4"x2-1/2"x21"
-
- Each 4' Extender
 - 2 - Roof Panels
 - 2 - Rafter 2-1/2"x3"x79-3/4"
 - 1 - Assembled Collar Tie Half

7-A: Make a mark on each of the roof panel ends 24" from the edge of the roof panel. Place the middle rafter 2-1/2"x3"x79-3/4" in the center of the roof panel, if the middle rafter has any slight bow, make sure to turn the bowed side against the roof boards for extra strength (see Diagram below). Temp spacer 3/4"x2-1/2"x21" can be used to help locate center of roof panel.

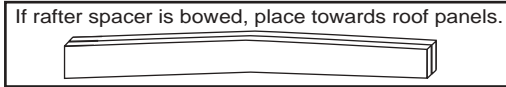

The center of the middle rafter should align with the center marks on the roof panel ends. Fasten (2) 3" screws through roof panel end into the middle rafter. You may need to move roof panel end to make it fit correctly. To do this loosen the screws on both ends of the end panel and slide the rafter to fit, then reattach the screws (B) into the roof panel end.

7-A

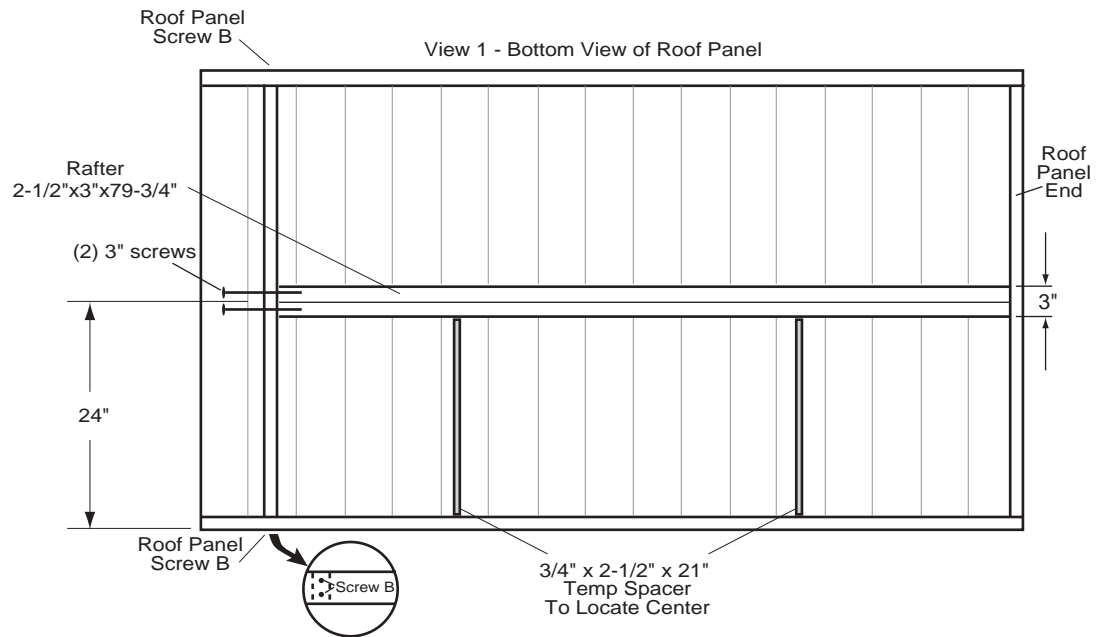

7-B

7-B: Turn the panel over to show the top view. Measure and mark 24" to locate middle rafter. Fasten 16 boards to the middle rafter using 1 - 2" screw in every board as shown. You can also use the 2 - 3/4"x2-1/2"x21" temporary spacers to keep the center rafter straight when fastening the roof boards to the middle rafter.

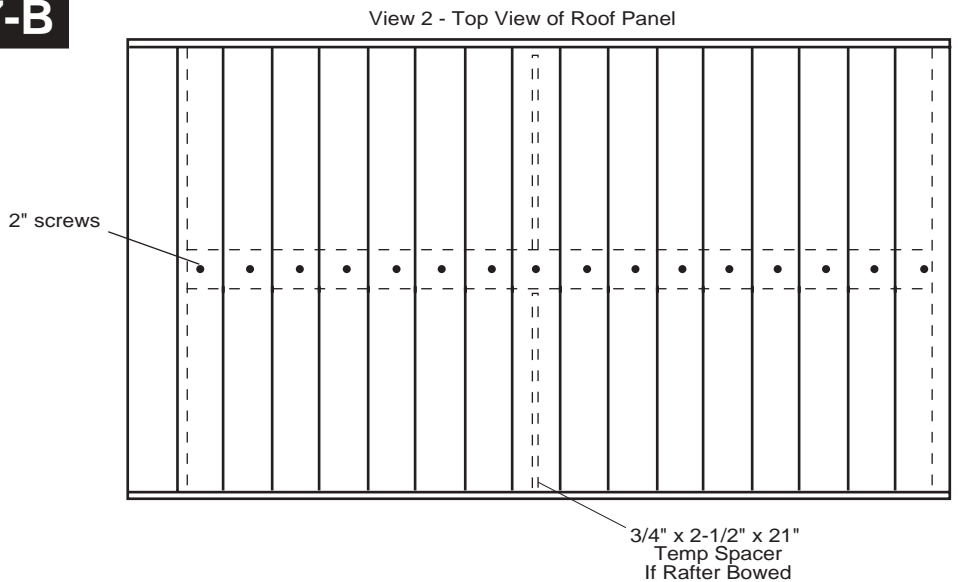

7

Installing Roof Panels Continued

7-C: Place the first roof panel on top of the side wall placing the notch tight against the side wall panel as shown and flush to the edge wall panel seam. The upper inside corner of the roof panel will not be resting on any structural member, so it will need to be temporarily propped up using the roof ridge support pole while you and a helper, screw the panel in place. Each roof panel is designed so that when it is correctly positioned the top edge of the side wall will fit into the notches in the rafters at the lower end of the roof panel. When attached to a gable at either the front or rear of the building, a roof panel must set back from the outside edge of the gable approximately 1/2".

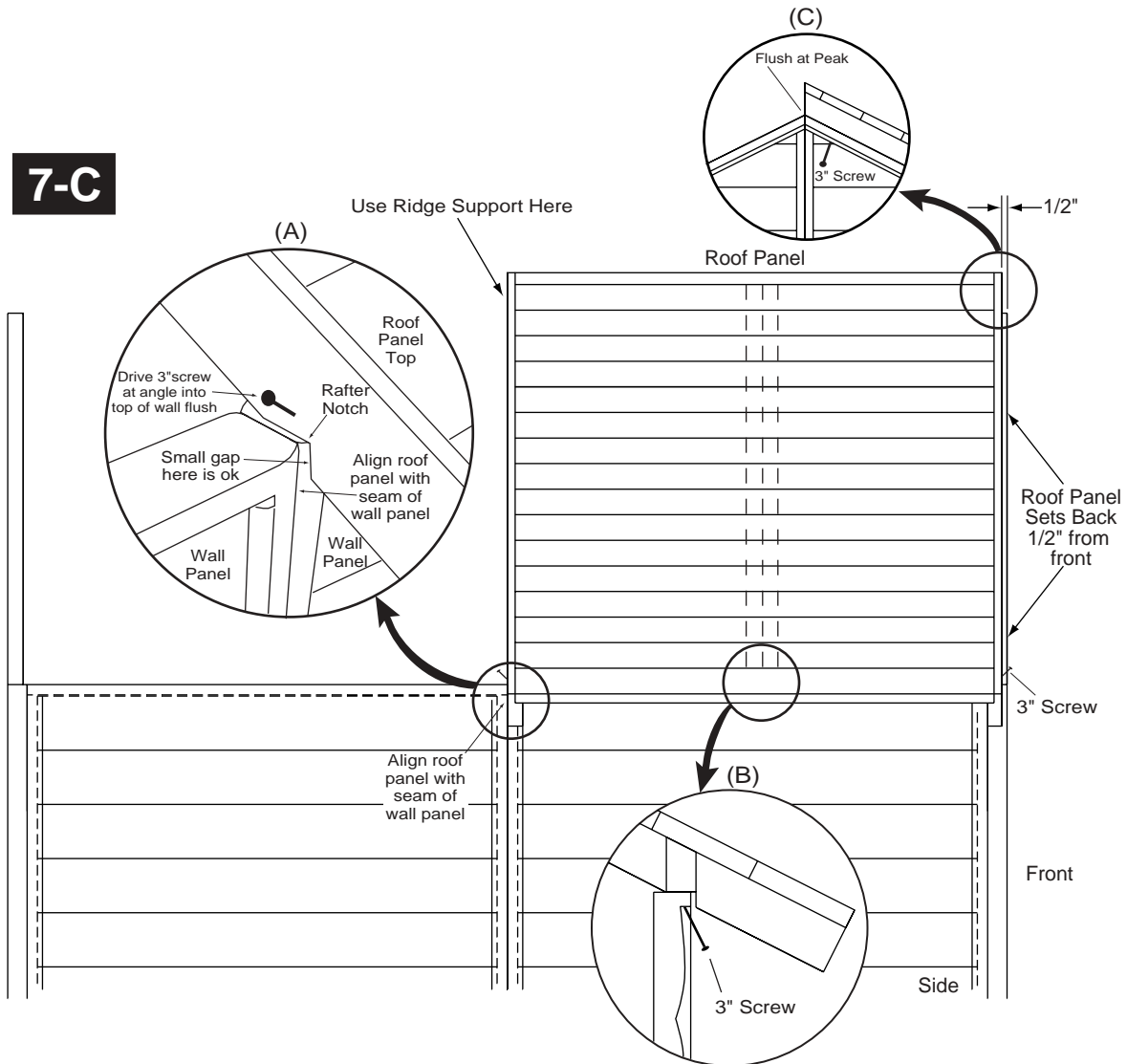

Raise roof panel and brace this roof panel in position using a support pole. Attach the lower edge of the roof panel to the wall it is resting on with one 3" screw at a slight angle through the panel's "rafters" into the top of the wall using one 3" screw per rafter as shown in (A) above. Secure with three 3" screw under side wall into each rafter of roof panel as shown in (B). Secure under gable panel with seven 3" screws as in (C) shown above and 7-D.

7

Installing Roof Panels Continued

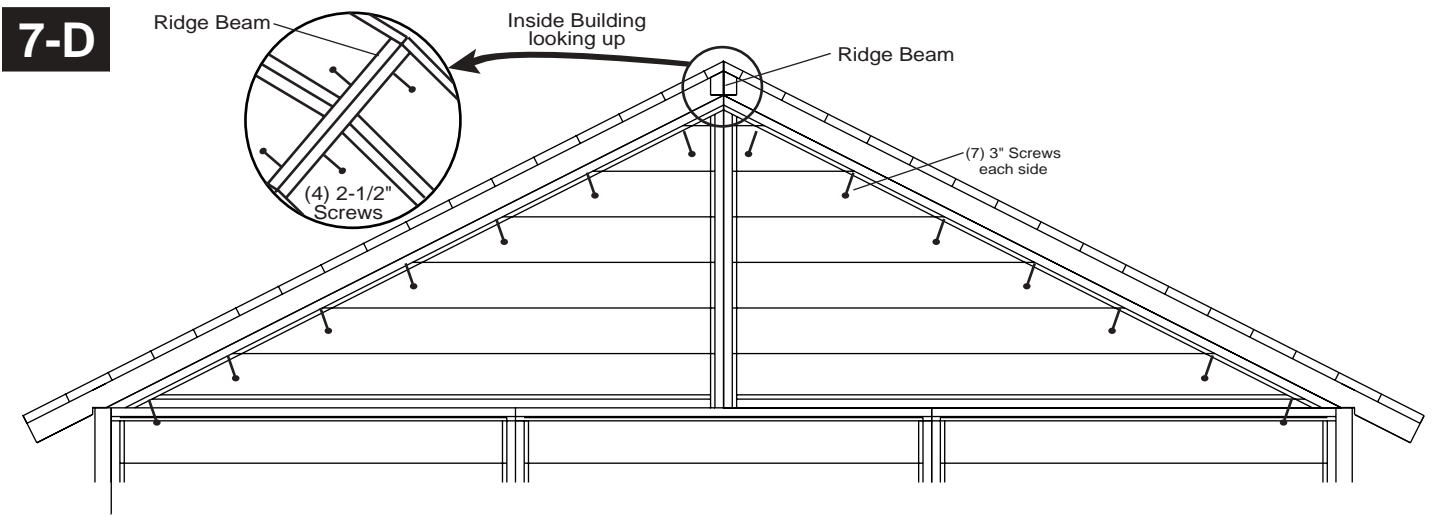

7-D: Select a 2nd roof panel & slide it upward along the gable from the right side of the building – opposite the 1st panel. As before, when the roof panel is correctly positioned, the top edge of the side wall will fit into the notches in the rafters at the lower end of the panel. Make sure both roof panels fit flush and level along the peak of the roof, then screw the panels together where they meet using (4) 2-1/2" screws evenly spaced across the span of the "ridge beam".

7-E: After installing the first two Roof Panels, position the assembled Collar Tie, level and tight against the Roof Panel on the inside. Fasten with 6 --2 1/2" screws at each end.

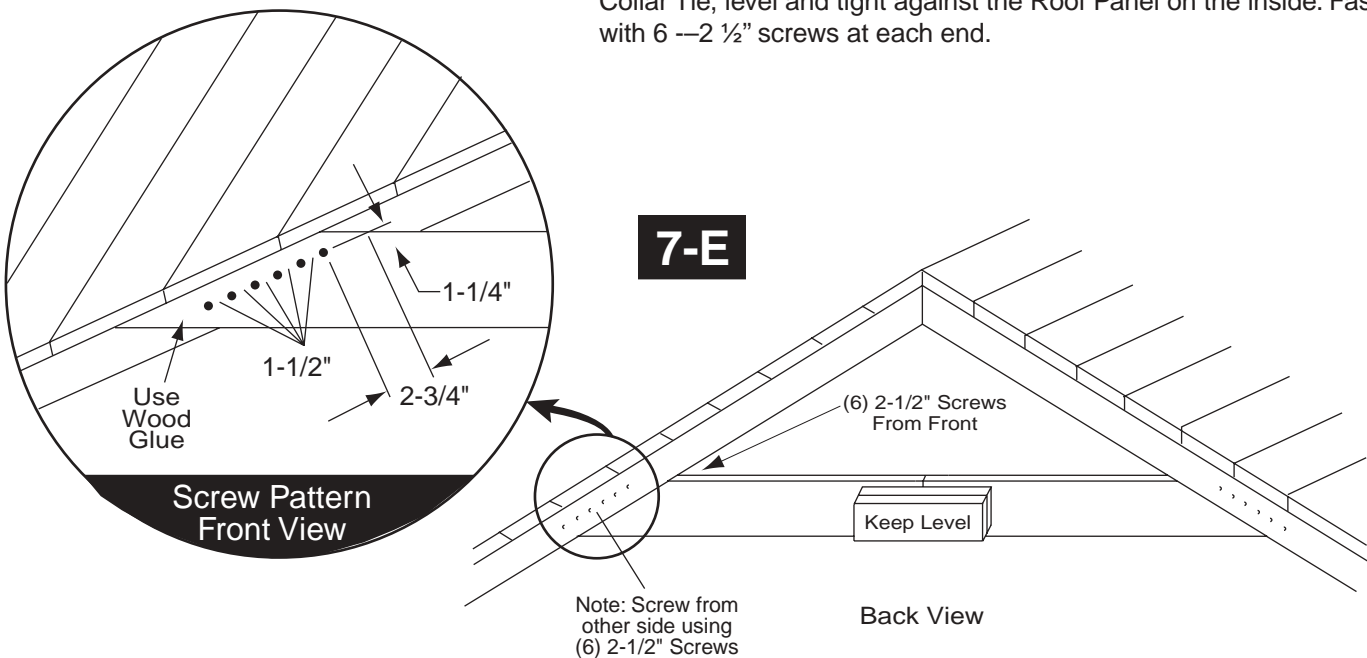

7

Installing Roof Panels Continued

7-F

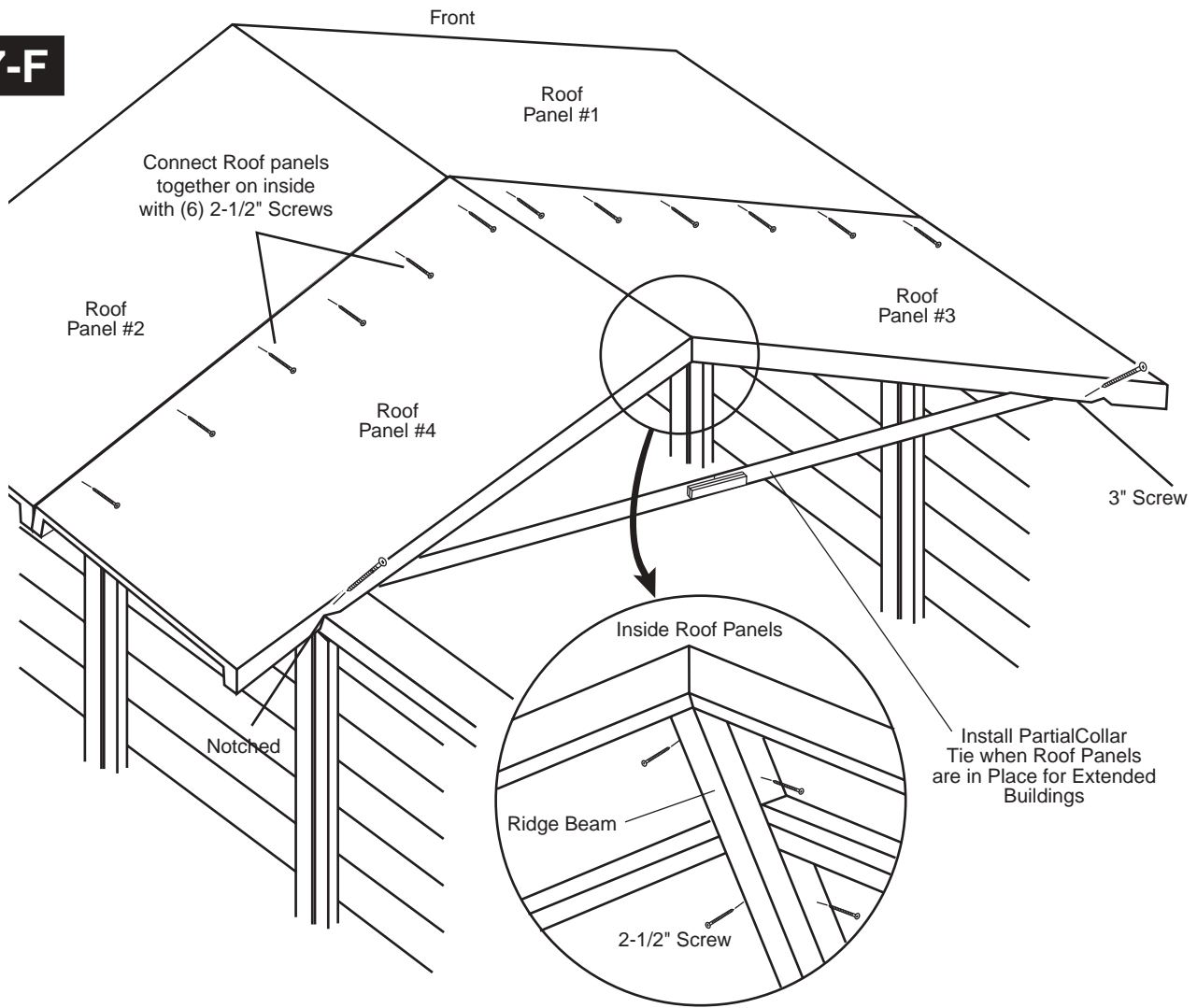

Note: Continue to move back wall brace from step 3A to next set of panels until all panel are installed.

7-F: Select a 3rd roof panel & slide it into position alongside the 1st roof panel installed. Using your temporary support pole prop up the new roof panel so that it is held in alignment with the rest of the roof & attach the 3rd panel to the wall it is resting on by screwing at a slight angle through the panel's rafters into the top of the wall using (1) 3" screw per rafter. Now, attach the 3rd panel's right rafter to the 1st panel's left rafter using (6) 2-1/2" screws. To ensure maximum strength, be sure to evenly space the screws across the rafters being fastened.

Slide a 4th roof panel into place from the right side of the building - opposite the 3rd panel installed - and after checking for alignment, screw the panels together where they meet using (4) 2-1/2" screws evenly spaced across the ridge beam. Then, attach the 4th panel's left rafter to the 2nd panel's right rafter using (6) 2-1/2" screws. For extended buildings, install another assembled collar tie between the 3rd & 4th roof panels - opposite the first collar tie installed - using (6) 2-1/2" screws in each end and making sure to keep the collar tie level. Continue installing roof panels in this manner moving toward the rear of the building.

7

Installing Roof Panels Continued

7-G: When placing the rear roof panels, slide them upward along the gable starting from the right side of the building. As before, when the roof panel is correctly positioned, the top edge of the side wall will fit into the notches in the rafters at the lower end of the panel. Secure with 3" screws at top of door and make sure both roof panels fit flush and level along the peak of the roof, then screw the panels together where they meet using (4) 2-1/2" screws evenly spaced across the span of the "ridge beam" from under gable using (7) 3" screws.

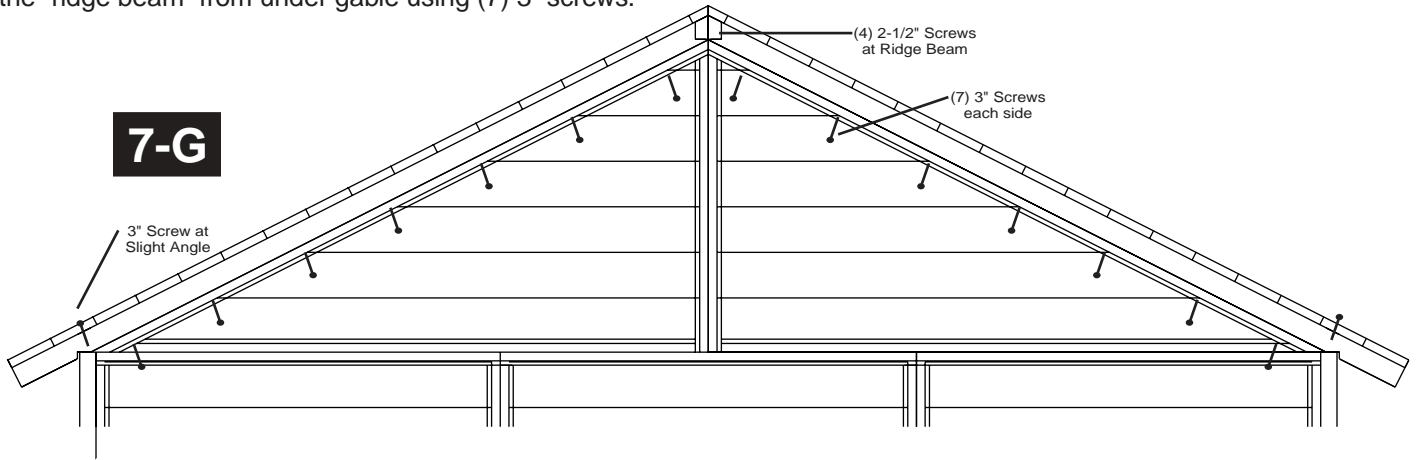

8

Installing Overhang Brace and Gable Brace

- 2 - Roof Panels
- 2 - Overhang Brace
- 1 - Assembled Gable Brace

8-A: Mount both overhang braces to the front of the building as shown using 9 - 3" screws per brace into the wall. Be sure to keep the brace flush with the top and side of the wall panel you are attaching it to.

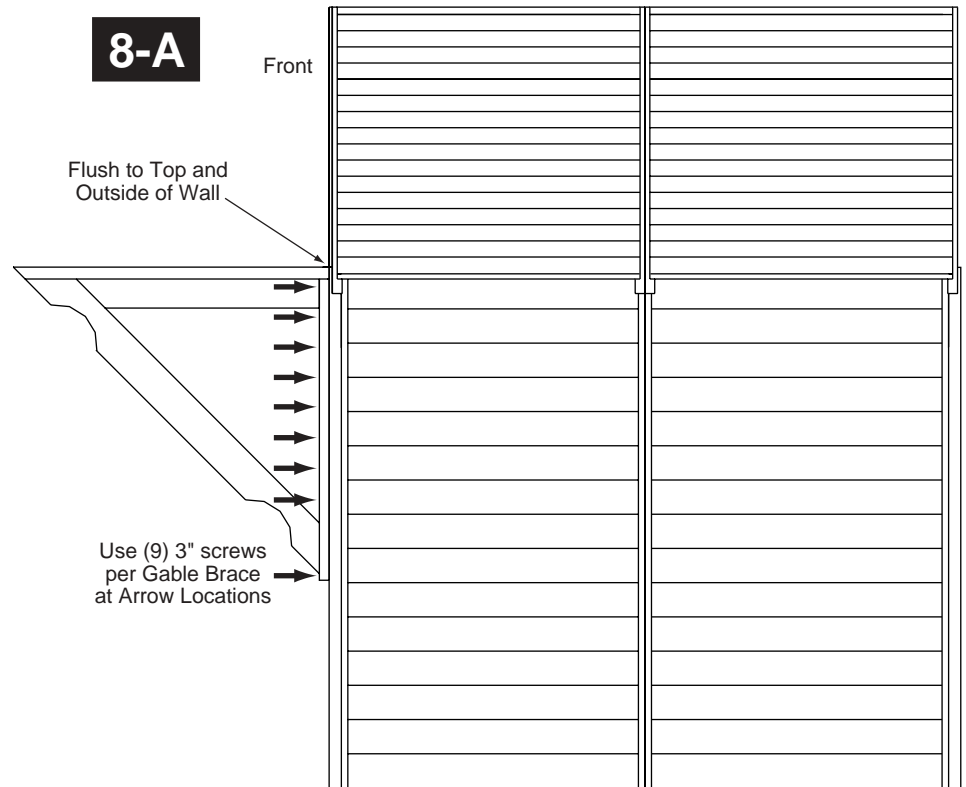

8 Installing Overhang Brace and Gable Brace

8-B

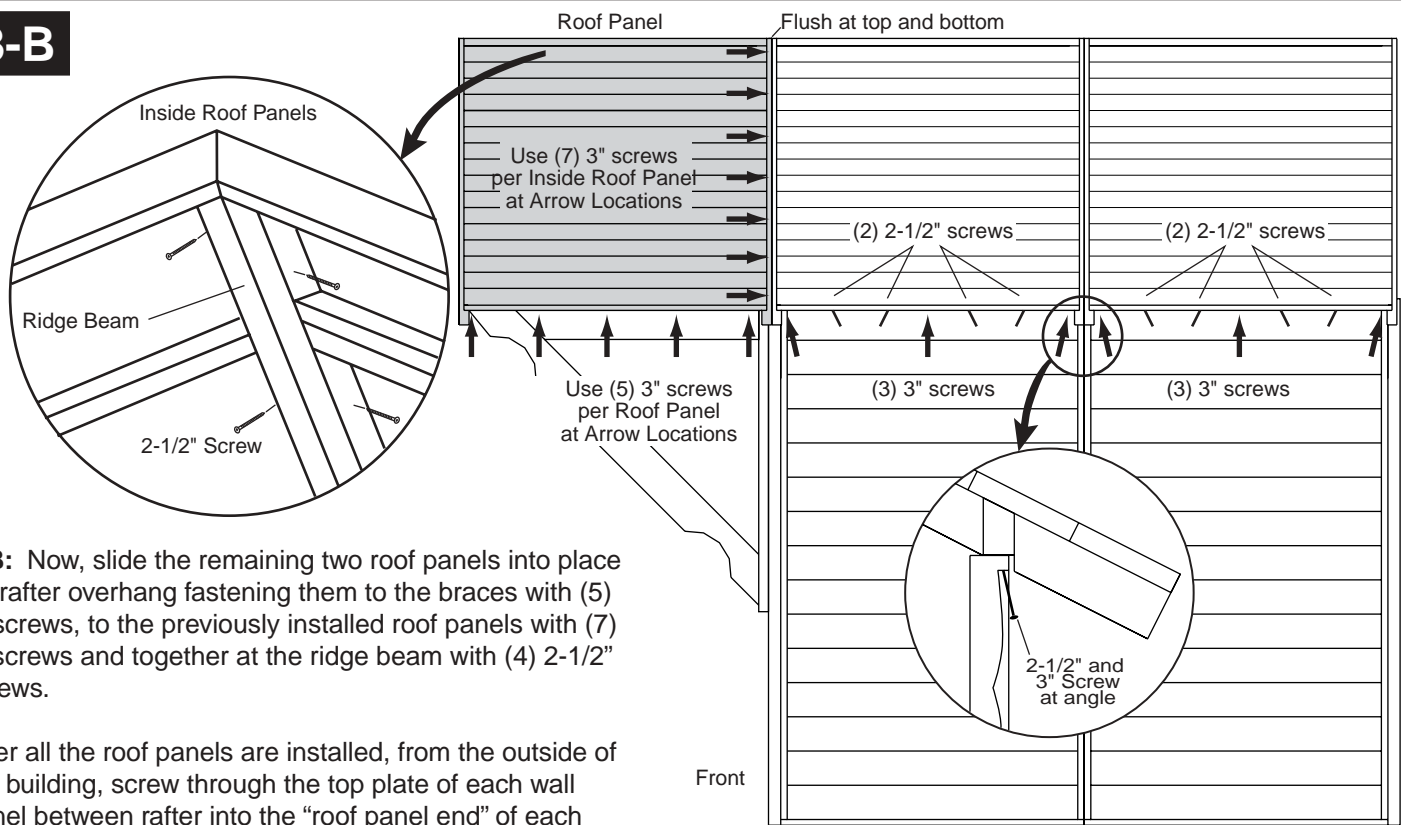

8-B: Now, slide the remaining two roof panels into place for rafter overhang fastening them to the braces with (5) 3" screws, to the previously installed roof panels with (7) 3" screws and together at the ridge beam with (4) 2-1/2" screws.

After all the roof panels are installed, from the outside of the building, screw through the top plate of each wall panel between rafter into the "roof panel end" of each roof panel using (4) 2-1/2" screws per panel.

8-C

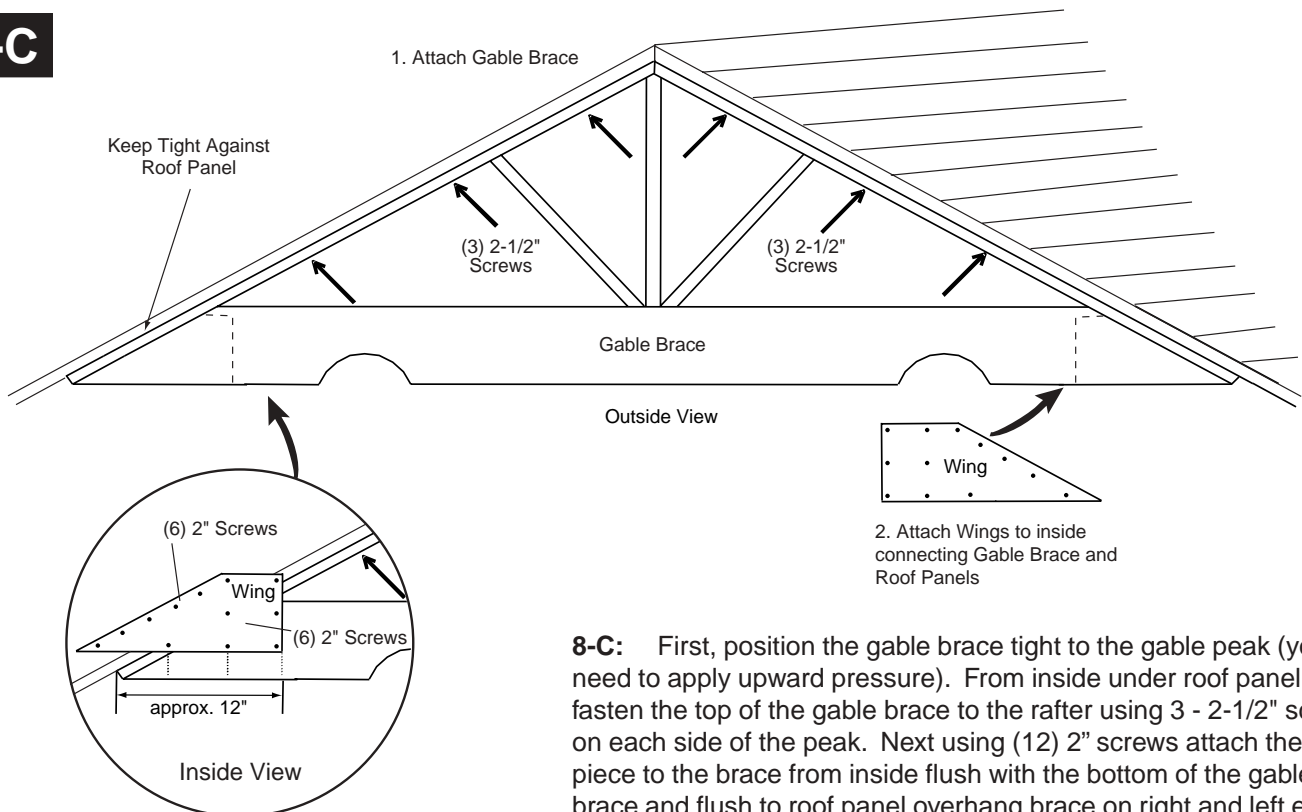

8-C: First, position the gable brace tight to the gable peak (you may need to apply upward pressure). From inside under roof panel, fasten the top of the gable brace to the rafter using 3 - 2-1/2" screws on each side of the peak. Next using (12) 2" screws attach the wing piece to the brace from inside flush with the bottom of the gable brace and flush to roof panel overhang brace on right and left end.

9

Installing Collar Tie and Gable Support Brace

- 2 - Angled Collar Tie 1x6x70"
- 2 - Collar Tie Filler 1x3x64"
- 2 - Gable Support Spacer (angled) 2x4x48"
- 2 - Collar Tie Decorative Connector 1x4x20"
- 2 - Collar Tie Support 1-1/2"x3-1/2"x22-3/4"

- Each 4' Extender
- 2 - Collar Tie Angled 1x6x70"
 - 2 - Collar Tie Filler 1x3x64"
 - 2 - Collar Tie Support 1-1/2"x3-1/2"x22-3/4"
 - 2 - Collar Tie Decorative Connector 1x4x20"

Note: If you are planning on installing a loft, some collar ties will not be used. A loft can only be installed in a 12x12, 12x16 and 12x20 Mackinaw. A 12x12 will have no collar ties, a 12x16 will have one collar tie and a 12x20 will have two collar ties if a loft is being installed.

9-A: Place two angled Collar Ties 1x6x70" opposite to the ones already installed, leveling as before. Secure in place with (6) 2-1/2" screws as in Step 5A on each end and center as shown. Use wood glue on all attachments.

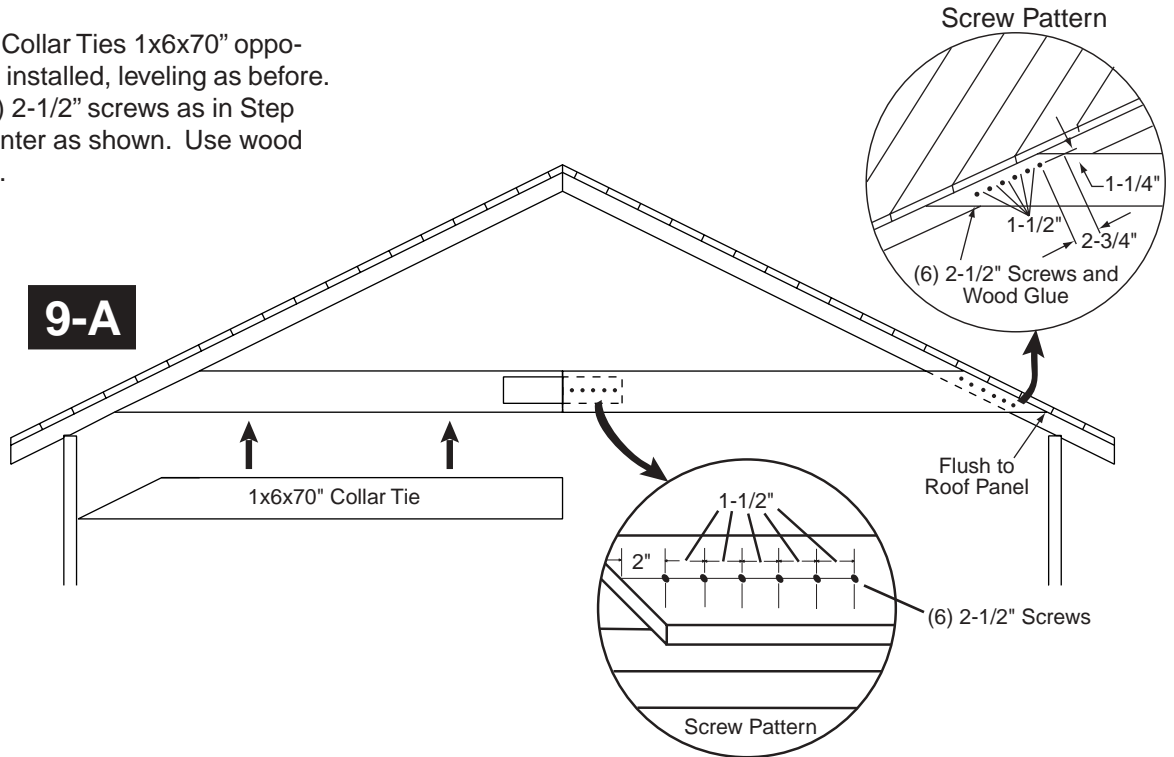

9-B: Install (2) 1x3x64" Collar Tie Filler to the underside and between the two angled side Collar Tie pieces, it should inset about 1/4" from edge. Use 2" finish Nails through sides into Filler 12" apart as shown.

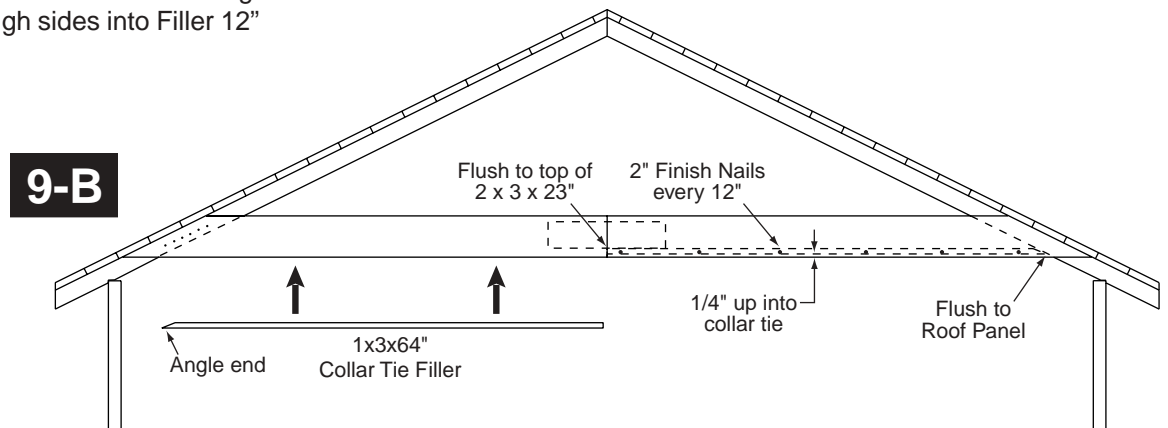

9

Installing Collar Tie and Gable Support Brace

9-C: Add 1x4x20 Cover over exposed screw heads at collar tie middle seam and fasten with (4) 2" finish nails on each as shown. Add 1-1/2"x3"x22-3/4" Collar Tie Support between the 1x6x70" Collar Ties and flush to rafters. Use (3) 3" screws as shown per side.

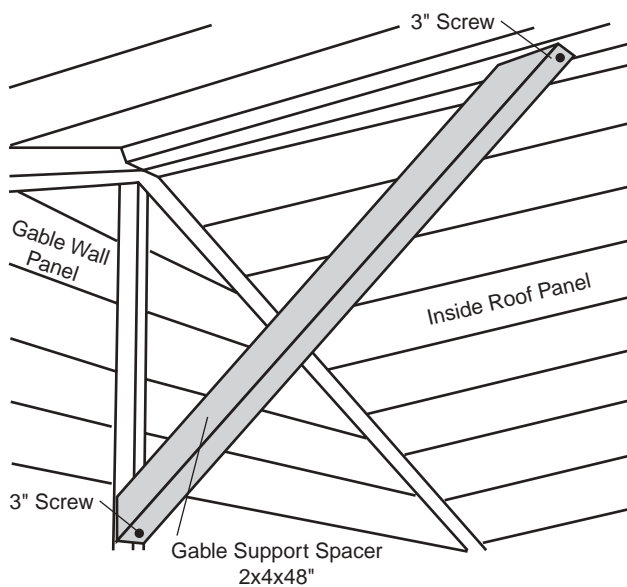
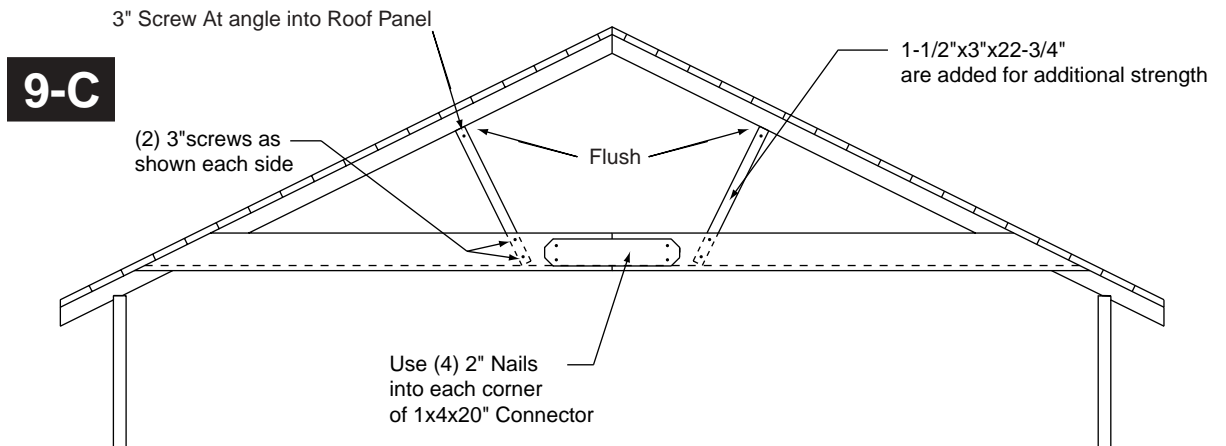

9-D: Attach both 2x4x48" pieces of inside gable support (between the gable & the ridge beam) using one 3" screw in each end.

10 Installing Finish Trim

- 2 - Gable Trim Front 1x4x90-1/2"
- 2 - Gable Trim (1-R & 1-L) Rear 2x4x90-1/2"
- 2 - Gable Channel Trim 2x4x36"
- 6 - Wall Channel Trim 2x4x80-3/4"
- 6 - Quarter Round Trim 1/4"x1"x80-3/4"
- 1 - Door Handle

- Each 4' Extender
- 2 - Wall Channel Trim 2x4x80-3/4"

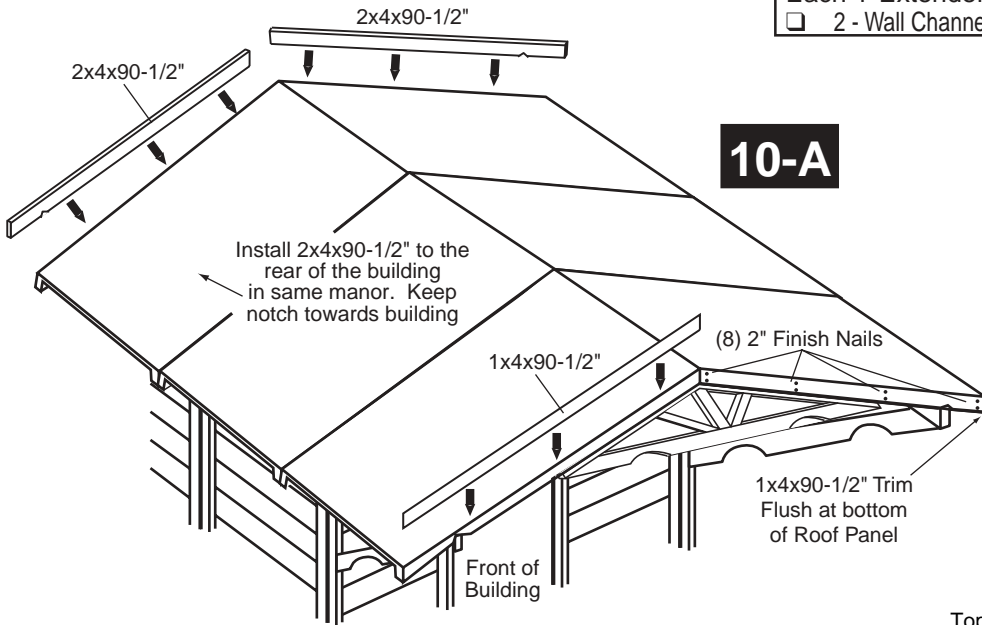

10-A

10-A: Install the 1x4x90-1/2" trim boards, with (8) 2" finish nails each, over the exposed face of the rafters on the two roof panels at the front of the building. Install 2x4x90-1/2" trim in the same manor to the rear of the building using 2-1/2" Screws. Place notched ends towards building and flush at the bottom of the roof panel.

10-B: Using (5) 2" finish nails fasten the quarter round trim equally spaced in the wall panel seams of the building.

10-B

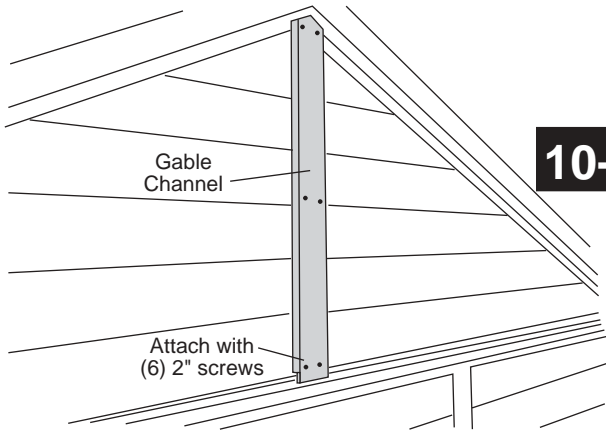
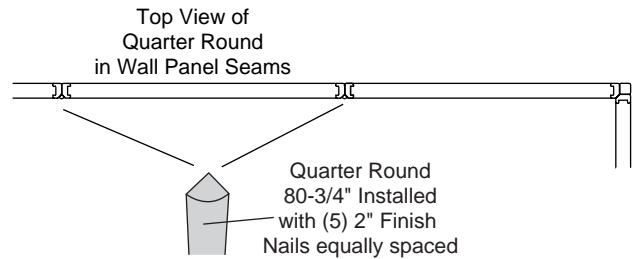

10-C

10-C: At each outside gable panel seam, caulk and fasten the Gable Channel trim in place using (6) 2" screws per piece.

10-D: At each outside wall panel seam, caulk and fasten the Wall Channel trim in place using (8) 2" screws per piece.

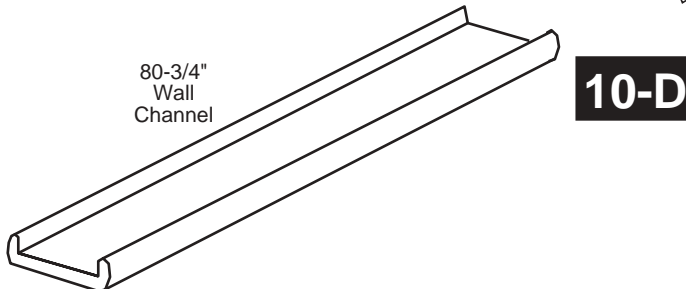

10-D

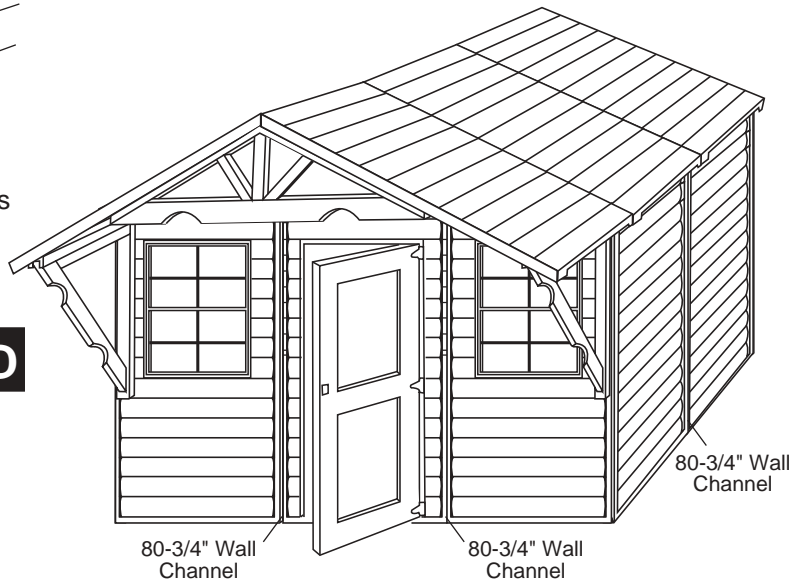

10-E: Install Door Handle with instructions provided with Door Handle. If missing, please call customer support.

11

Painting, Shingles and General Maintenance

Your Mackinaw Timber building, like your home, requires a certain amount of normal maintenance and care.

Caulking:

You will want to caulk at exposed seams, both horizontal and vertical, with a good grade of exterior caulk.

12' x 8' - 3 tubes, 12' x 12' - 4 tubes, 12' x 16' - 5 tubes, 12' x 20' - 6 tubes

**Important Notice*

Gable seams and side wall seams at floor must be caulked on each panel.

Painting or Staining:

All exposed edges of your building must be stained or painted, both inside and outside, with a good grade of exterior stain or paint. The bottom edges are most important. Periodic refinishing, as weather conditions demand, is also necessary.

12' x 8' - 2 Gallons, 12' x 12' - 2 1/2 Gallons, 12' x 16' - 3 Gallons, 12' x 20' - 4 Gallons

Shingles:

Your timber building must be shingled. We recommend that a drip edge also be applied before shingling. When shingling follow manufacturer's installation instructions.

INSTALLING DRIP EDGE (RECOMMENDED)

Install Drip Edge to outside edges of Roof Panels, overlapping pieces by 1"(2.5cm). You may need to use more than one piece if it does not span the whole distance.

Once Drip Edge is in place, nail or screw with 3/4" (1.9cm) nails every 8"(20.3cm).

With the sides completed, install Drip Edge to Gable End. Use one piece to start and flush it to the bottom of the side Drip Edge. Nail in place, even though it will extend off the roof. Once in place, snip bottom half of Drip Edge at Peak and bend over onto other side of Gable as shown. You may need to use two pieces. Overlap pieces by 1"(2.5cm).

Once Drip Edge is in place, nail or screw with 3/4" (1.9cm) nails every 8" (20cm).

Building Size

12' x 8'
12' x 12'
12' x 16'
12' x 20'

Shingles Required

2-1/2 sq. - 7 Bundles
3 sq. - 9 Bundles
3-2/3 sq. - 11 Bundles
4-1/3 sq. - 13 Bundles

Felt Paper

168 sq. ft.
224 sq. ft.
280 sq. ft.
336 sq. ft.

Drip Edge

50 lin. ft.
60 lin. ft.
70 lin. ft.
80 lin. ft.

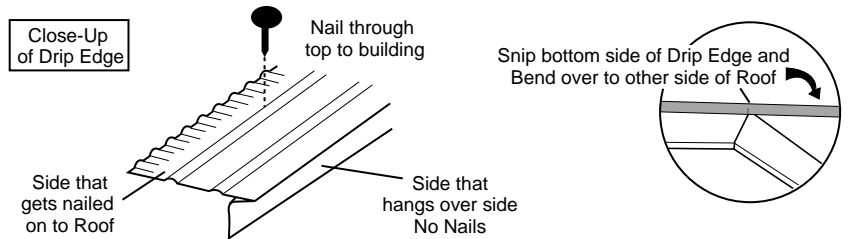

INSTALLING SHINGLES (REQUIRED)

Using four nails per shingle, nail as shown in drawing. Drive nails straight so that the nail head is flush with, but not cutting into shingle surface.

Follow illustrations to apply Shingles to your Building.

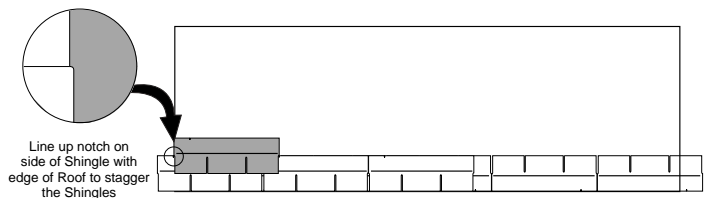
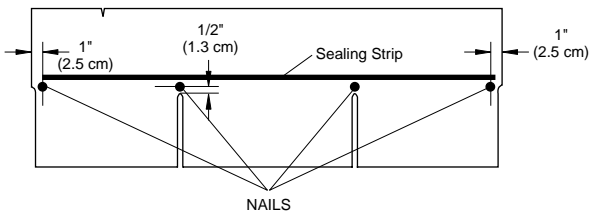

After completing shingling your building, remove any overhanging, excess shingles by cutting them off with a utility knife.

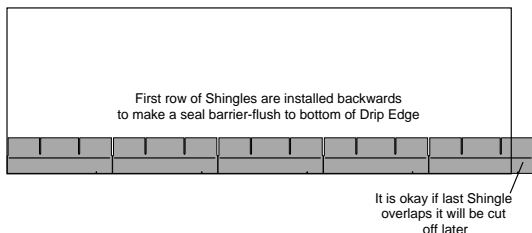
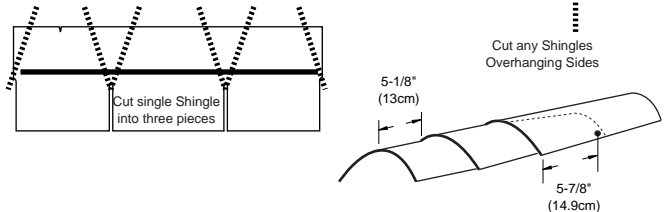
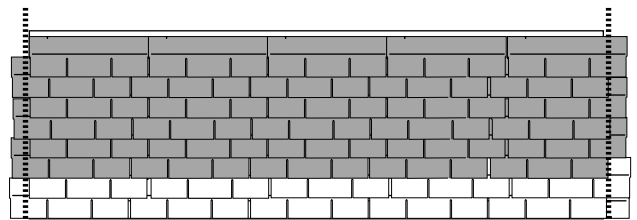



Limited Conditional Warranty *

WARRANTY

Handy Home Products warrants the following:

1. Every product is warranted from defects in workmanship and manufacturing for one year.
2. All hardware and metal components are warranted for two years.
3. Trim is warranted for 10 years.
4. Waferboard siding and sheathing is warranted for two years.
5. SmartSide™ siding is warranted for 10 years on all Marco series buildings and 15 years on all Premier Series buildings.
6. Mackinaw series buildings' siding and trim are warranted for 10 years.
7. Phoenix Solar Shed windows are warranted for 1 year.
8. Cedar lumber is warranted for 15 years.

Handy Home Products will repair, replace or pay for the affected part. In no event shall Handy Home Products pay the cost of labor or installation or any other costs related thereto. All warranties are from date of purchase. If a cash refund is paid on an affected part, it will be prorated from the date of purchase.

CONDITIONS

The warranty is effective only when:

1. The unit has been erected in accordance with the assembly instructions.
2. The unit has been properly shingled and painted or stained and regularly maintained thereafter.
3. The failure occurs when the unit is owned by the original purchaser.
4. Handy Home Products has received the warranty registration card within thirty (30) days of purchase and notification of the failure in writing within the warranty period specified above.
5. Handy Home Products has had reasonable opportunity during the sixty (60) days following receipt of notification to inspect and verify the failure prior to commencement of any repair work.

REQUIREMENTS

Storage Buildings & Playhouses

To validate your warranty, it is necessary to properly maintain your Handy Home Products unit; shingle the roof and paint or solid-colored stain the siding using 100% acrylic latex exterior product with a minimum of two (2) coats within thirty (30) days of assembly; caulk above all doors and all horizontal and vertical trim boards; paint and seal all exposed edges, sides and faces of SmartSide™ and waferboard siding to include all exterior walls and all sides and all edges of doors.

Gazebos & Timber Buildings

To validate your warranty, it is necessary to properly maintain your Handy Home Products unit. This includes treating all of the exposed cedar and pine surfaces on your gazebo or timber building with an exterior grade wood preservative, an exterior oil-based semi-transparent stain, an acrylic latex exterior paint or an acrylic latex solid color exterior stain within 30 days of assembly and as needed thereafter to maintain your warranty.

Keep vegetation trimmed away from building and make sure siding panels and trim do not come in contact with masonry or cement. The minimum ground clearance for siding must be one half inch (½ inch) from concrete slab or two and one half inches (2 ½") from the ground when building is erected or constructed on a treated wood floor kit. Water from sprinklers must be kept off unit. In no event will Handy Home Products be responsible for any indirect, incidental, consequential or special damages nor for failure(s) that are caused by events, acts or omissions beyond our control including, but not limited to, misuse or improper assembly, improper maintenance (which eventually leads to rot or decay) and acts of God. Handy Home Products will not be held responsible for any labor costs incurred to construct your unit. This warranty gives you certain specific rights that vary from state to state.

CLAIM PROCEDURE

To make a claim under this warranty, you can either call (800) 437-0784 or prepare a letter. Please have ready the information below when you call or include the information when writing:

1. The model and size of the product.
2. A list of the part(s) for which the claim is made.
3. Proof of purchase of the Handy Home Products' item, as shown on the original invoice.
4. Run code, as listed on the yellow warranty card enclosed in the product package.

Mail the above information to:
Handy Home Products
Attn: Customer Service
6400 E. 11 Mile Road
Warren, MI 48091

***WARRANTY TERMS MAY VARY OUTSIDE THE U.S.A.**

IMPORTANT: This is your warranty certificate.

Please complete and mail your warranty card to properly validate your warranty.